

Projection Screens

reflecta®

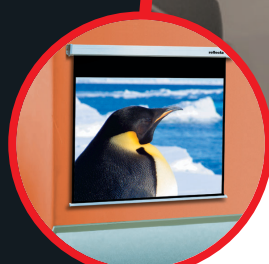

The right projection
screen for your
specific purpose

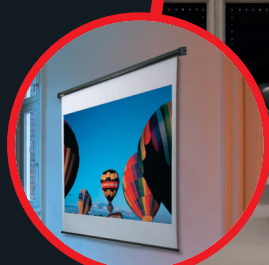
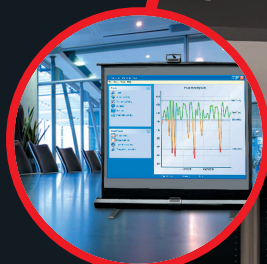
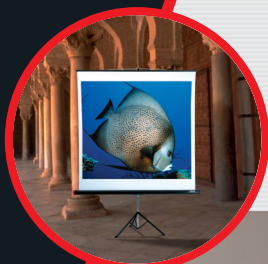

THE ENTIRE UNIVERSE OF PROJECTION SCREENS
PROJECTION SCREENS BY REFLECTA

reflecta



Contents

reflecta4
Basics6
Projection screen know-how7
reflecta screen fabric terminology.....8

Portable projection screens

Stative.....Alpha10
.....CrystalLine.....11
.....SilverLine GF.....12



.....Cinemobil.....13



PortabelTable screen.....14
.....BFloor screen.....15



Landscape format16



Alum. frame..QuickSet18



Fixed projection screens

Spring roller20



Galaxy, Self-locking roller system21



CrystalLine ...Rollo/Rollo Softlift/Motor.....22



Silverline/Whiteline....Rollo/Motor.....24



Superior Motor.....26

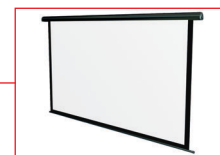

Cosmos N Motor28



Cinehome30



reflecta

Quality and innovation in photography - this has been the hallmark of reflecta for more than 35 years. The history of our company started with the production of projection lamps and photo accessories in 1967 – today, we offer customised solutions for presenting and processing photos for almost any purpose.

To make the best out of your photos, we make the highest demands in quality to ourselves. Time and again, our innovative products have shown that the good can still be made better. We are committed to our tradition. Therefore, we do not twiddle our thumbs, not even in the age of digital photography and image processing. At reflecta, you will find novelties for all aspects of photography. Quality and innovation – to make only the best of your photos.

Chronology

- 1967 reflecta foto-film-projektion was established in Nuremberg. Product range: projection lamps and photo accessories.
- 1970 Company moved to Schwabach near Nuremberg. Production of film and photo lights was started, distribution of flashguns, projection lamps, flash lamps and cubes.
- 1974 Production of reflecta projection screens was started.
- 1977 reflecta superstar screen for daylight projection was introduced. At the time, it was the brightest screen due to a completely new procedure of surface coating.
- 1980 Another projection screen, the reflecta pearly screen, with a specially finished surface for highest colour luminance and authentic colours was introduced.
- 1982 The reflecta system 4000 for tripod projections screens was introduced.
- 1999 Projection screen product range was expanded to home theatre applications.
- 2006 Projection screen product range was expanded significantly.
- 2007 New screen series CrystalLine was introduced which involved an expansion of warehouse grounds to over 4,000 sq..
- 2010/ 2012 reflecta participated in Europe's most important exhibition for screens and AV technology, the ISE (Integrated System Europe) in Amsterdam.



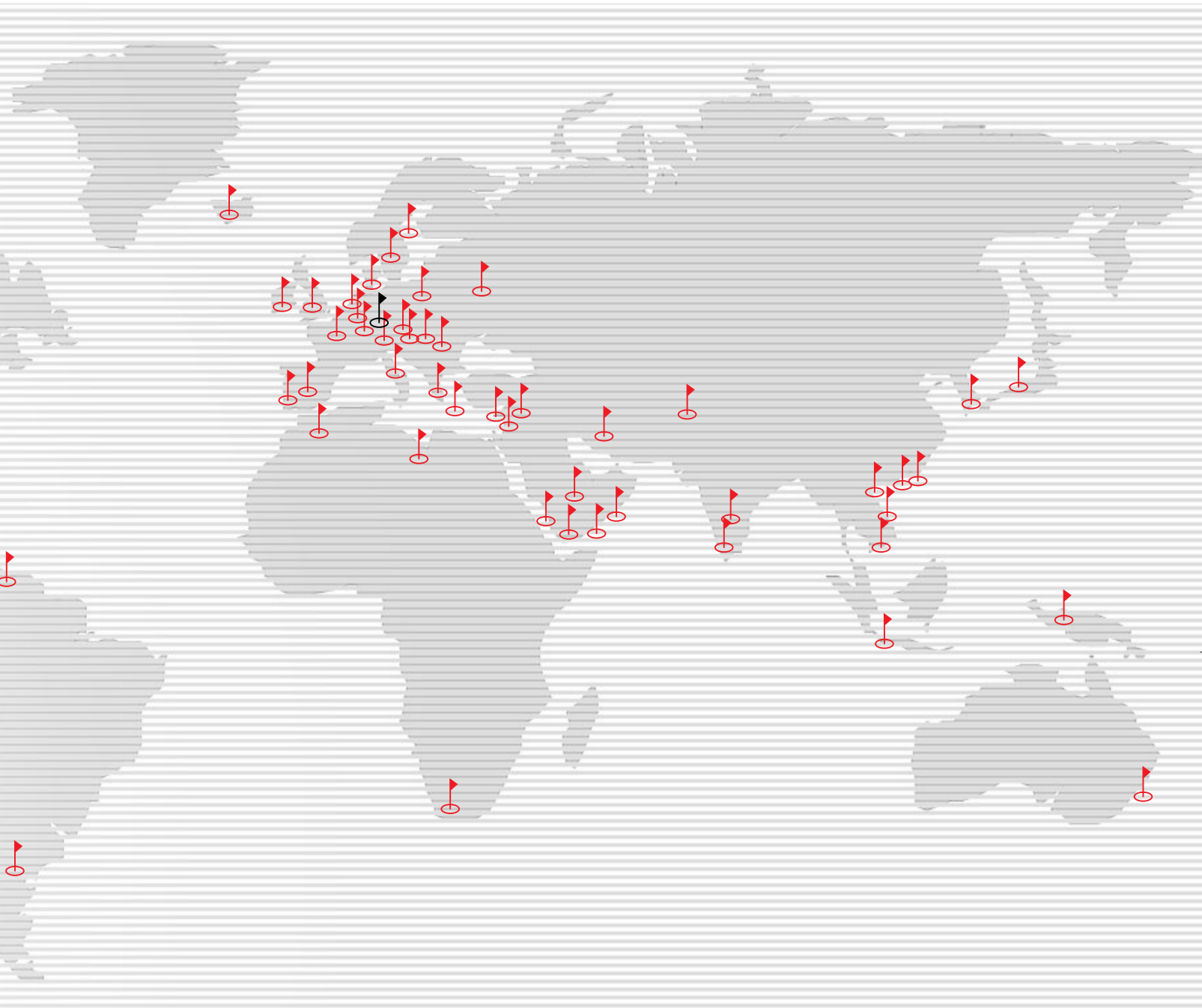

**reflecta
worldwide**

Europe

- Belgium
- Cyprus
- Denmark
- Great Britain
- Finland
- France
- Greece
- Netherlands
- Ireland
- Island
- Italy
- Luxembourg
- Austria
- Poland
- Portugal
- Romania
- Sweden
- Switzerland
- Slovenia
- Slovakia
- Spain
- Czech Republic
- Hungary

North America

- Canada
- U.S.A.

South America

- Argentina
- Venezuela

Middle East

- Iran
- Israel
- Yemen
- Kuwait
- Oman
- Palestine
- Saudi Arabia
- Syria

Asia

- Bangladesh
- Hong Kong
- India
- Indonesia
- Japan
- Korea
- Malaysia
- New Zealand
- Pakistan
- Russia
- Singapore
- Sri Lanka
- Taiwan
- Thailand
- Vietnam

Africa

- Morocco
- South Africa
- Tunisia

Purchasing references at mail@reflecta.de



Basics about the fabrics

If you want to present pictures or information to an audience, be it in the private or business sector, a perfect presentation is indispensable.

However, this can be achieved only if projection device and screen match each other. A slide projector, e.g., needs a different screen than a beamer. Before purchasing a screen, you should therefore think carefully about the intended purpose.

In the private sector, different factors are decisive than when used in the business world. When used at home, the pure pleasure of watching the presentation is in the foreground; when the screen is not required, it should be hidden unobtrusively. In the business area, a stable design to withstand daily use and versatile applications is required.

Basics about brightness

In order to view a projected picture, the picture must have a certain brightness. This brightness, of course, depends on the light in the room, and the picture must be brighter than the surrounding light. It is also clear that in bright rooms, the pictures must be proportionately brighter than in dark rooms.

A decisive parameter of all projectors is their light intensity. For multimedia projectors, this intensity is measured in lumen, where the standard of the American National Standard Institute (ANSI) is applied frequently.

The larger the projection surface, the lower the amount of light per surface unit since projectors – irrespective of the size of a picture – always produce the same amount of light.

part from light intensity, the contrast value is an essential factor which influences the quality of the projected image. The contrast value indicates the ability of a projector to reflect a scale of shades as wide as possible in their colour intensity from the darkest to the brightest shade as in real

life. A high contrast will produce a natural, vivid image.

Hence, luminous efficacy and contrast value must match the brightness of the ambient light and the characteristics of the projection screen to produce a perfect image.

The ratio between the brightness of the projector and that of the projected image should be 5:1 as a minimum to achieve the best image quality.

A. Trapezoid distortion

Front projections typically produce a trapezoid distortion (keystoning). The projected picture is larger at the top of the screen than at the bottom. This distortion is caused by an inclined projection onto a straight hanging screen. Special keystone eliminators allow for an inclined positioning of the screen to provide for an appropriate means to avoid the trapezoid distortion when using OHP. With the modern data and video projectors, the trapezoid effect can also be avoided or reduced with the keystone eliminators.

B. Gain factor

The gain factor describes the luminance of a fabric or a projection screen. The higher the gain, the stronger the reflection of the screen fabric. With an increasing gain factor, the viewing angle of the screen decreases.

C. Angle of view

The angle of view describes the angle in degree where the picture on the screen is still adequately visible. It is measured with reference to the normal of the screen center. The double angle of view (= viewing angle) thus describes the area within which an audience should be seated.

D. Selecting the right screen

Selecting the right screen depends on four variables:

1. Type of screen

- Rear or front projection (the latter is the most common method).
- Mounted firmly or portable.
- Operated electrically or manually.

2. Screen size

- Depends on projection room and seating arrangement.
- Ideally, the following criteria are considered:
 - The screen width (X) should amount to at least half the distance between screen and first row of seating (D1) (example: With a distance of 4 metres between the first row and screen, the minimum screen width is 2 metres).
 - The distance between screen and last row of seating (Y) should not be larger than 6 times the screen width (X) (example: With a screen width of 2 metres, the last row should be at 12 metres as a maximum).
 - The distance between floor and bottom edge of screen (A) is 90 cm, preferably 125 cm for row seating.

3. Screen format

It is determined by the projection method. The format (also referred to as aspect ratio) is defined by the ratio of height to width of the screen. Depending on the projection type, the following formats are distinguished:

- 1:1 for overhead projection (also referred to as square)
- 4:3 for video projection (also referred to as NTSC or video)
- 3:2 for slide projection
- 16:9 for widescreen projection

4. Type of fabric

The type of fabric is determined by the following factors:

- The projection method (front projection or rear projection).
- The projector. Each projector has a specific luminous efficacy (measured in ANSI lumen). If several projection devices are used (e.g. beamer and OHP), it is recommended to match the luminance (gain factor) of the fabric to the lowest ANSI lumen value.
- The size of the projection room. The size and the layout determine the seating of the audience. The wider the seats are apart, the larger the recommended viewing angle of the screen.
- The ambient light.
 - The lighting conditions of the projection environment affect the presentation quality. When the lighting can be controlled, e.g. by darkening or a high luminance of the projector, the "SuperLux" fabric can be used.
 - The rule of thumb is: keep the ambient light away from the screen; the brighter the ambient light, the higher the luminance of the projector and/or reflection of the fabric should be.
 - Rear projection is substantially more insensitive to ambient light!

E. Care of screens

Frequent use of a screen requires an appropriate care. All screens can be cleaned with a carefully applied weak soapsuds. When not in use, the screens should be retracted to their casing to protect them against depositing dust.

Avoid to touch the screen fabric with bare hands since, in the course of time, dust will stick better to the (greasy) imprints than on clean spots.

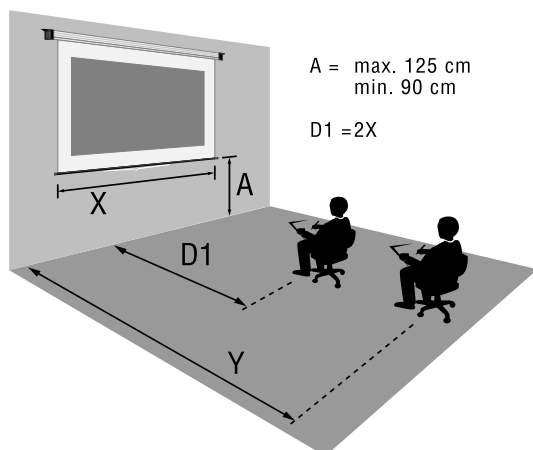

The fabric types

A projection screen does not only refract the projected light, but also distributes it with a single goal: send as much light as possible into the direction of the audience.

There are two types of projection screens:

- Diffuse
- Reflective

Gain

The reflection properties of a screen are defined by the gain or luminance factor. This factor informs you of the luminance of the respective projection screen in comparison to a surface that is standard white-coated. The factor expresses how many times lighter the picture is seen by the viewer. The larger the gain factor of a screen, the smaller the viewing angle. Typically, the specified gain factor indicates the maximum reflection of a screen along the projection axis. Special coatings of the projection screens are used to obtain different reflection characteristics. Their effect is to manipulate the light reflection, i.e. either distributed evenly in all directions or concentrated to a small viewing angle.

AlphaLux

Characteristics:

- Gain 1.1
- Viewing angle 120°
- Weight/m² 360 g
- Screen thickness 0.28 mm

Used for:

Tripod Alpha, Cinemobil and spring roller

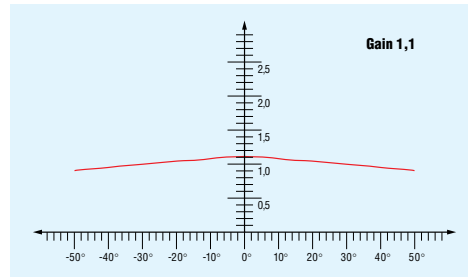

TwinLux

Characteristics:

- Gain 1.1
- Viewing angle 120°
- Weight/m² 360 g
- Screen thickness 0.28 mm

Used for:

Tripod Alpha TwinLux

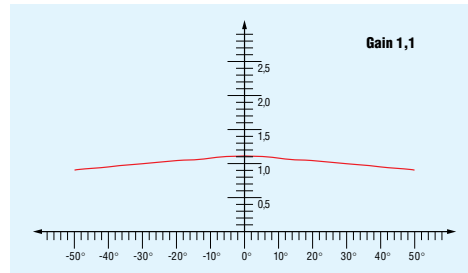

GammaLux

Characteristics:

- Gain 1.0
- Viewing angle 160°
- Weight/m² 380 g
- Screen thickness 0.28 mm

Used for: Ultra-portable table screen and portable floor screen

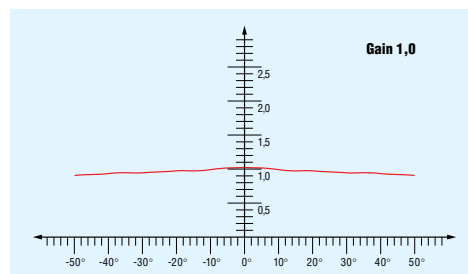

UltraLux

Characteristics:

- Gain 1.2
- Viewing angle 120°
- Weight/m² 570 g
- Screen thickness 0.40 mm
- Fire protection class M1

Used for: Landscape formats, tripod, self-locking roller Silverline or electric Silverline/WhiteLine, Superior

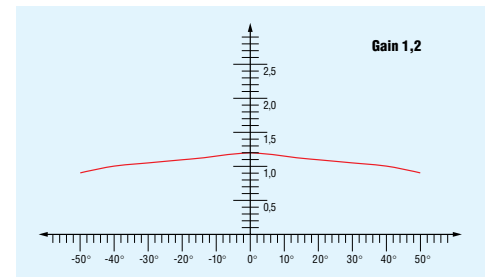

ValueLux

Characteristics:

- Gain 1.2
- Viewing angle 150°
- Weight/m² 601 g
- Screen thickness 0.40 mm

Used for:

Cosmos series

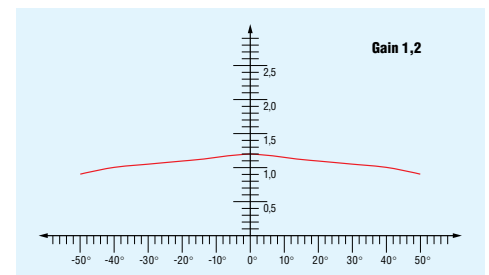

DeltaLux

Characteristics:

- Gain 1.0
- Viewing angle 160°
- Weight/m² 440 g
- Screen thickness 0.40 mm

Used for:

Galaxy series Self-locking roller

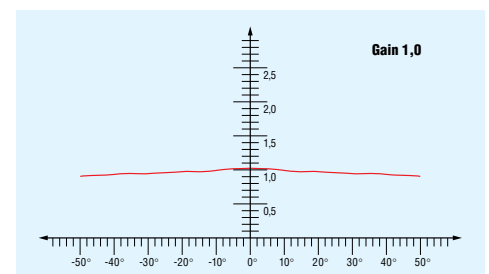

UltraLux for mobile front projection

Characteristics:

- Gain 1.0
- Viewing angle 100°
- Weight/m² 295 g
- Screen thickness 0.22 mm

Used for:
QuickSet

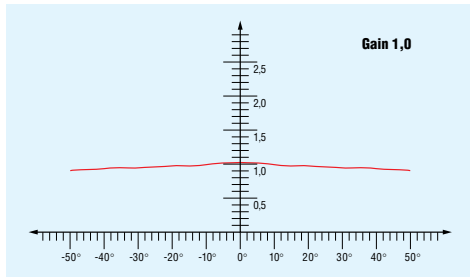

RearPro

Characteristics:

- Gain 1.6
- Viewing angle 120°
- Weight/m² 420 g
- Screen thickness 0.32 mm
- Fire protection class M1

Used for:
Self-locking Silverline rear projection

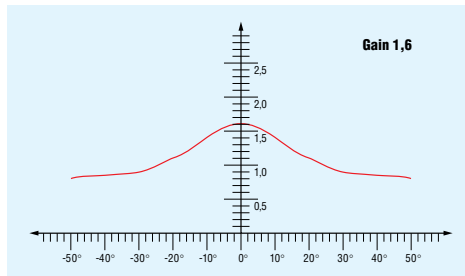

SigmaLux

Characteristics:

- Gain 1.0
- Viewing angle 160°
- Weight/m² 370 g
- Screen thickness 0.35 mm

Used for:
CineHome

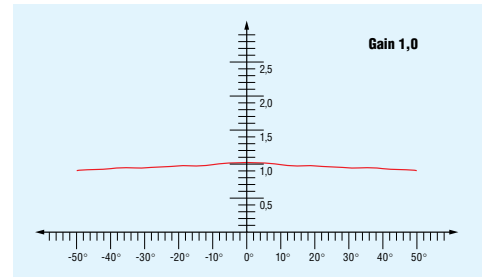

UltraLux for mobile rear projection

Characteristics:

- Gain 1.2
- Viewing angle 100°
- Weight/m² 370 g
- Screen thickness 0.28 mm

Used for:
Quickset

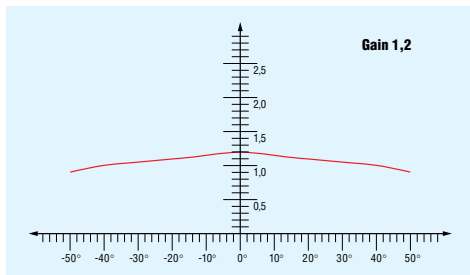

BetaLux

Characteristics:

- Gain 1.0
- Viewing angle 120°
- Weight/m² 300 g
- Screen thickness 0,35 mm

Used for:
CrystalLine Tripod, self-locking roller, electric

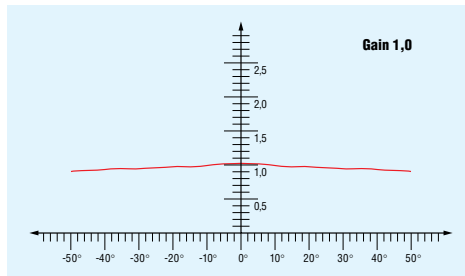

Tripod Alpha

Well-priced projection screen designed for the fast mobile use.

Product details:

- Black metal tube in appealing design, 6 cm diameter.
- Tripod with anti-skid plastic caps on legs for a safe stand.
- Ergonomically designed carrying handle with lock.
- Perfectly plain position of the screen due to a tensioning mechanism at the tube.
- Continuously adjustable height of horizontal tube and telescopic tube.
- Projection screen can be rotated vertically by 360°.
- Projection screen in AlphaLux, SilverLux or TwinLux matte white, 1.1 gain and wide viewing angle.
- Optional carrying bags for all sizes

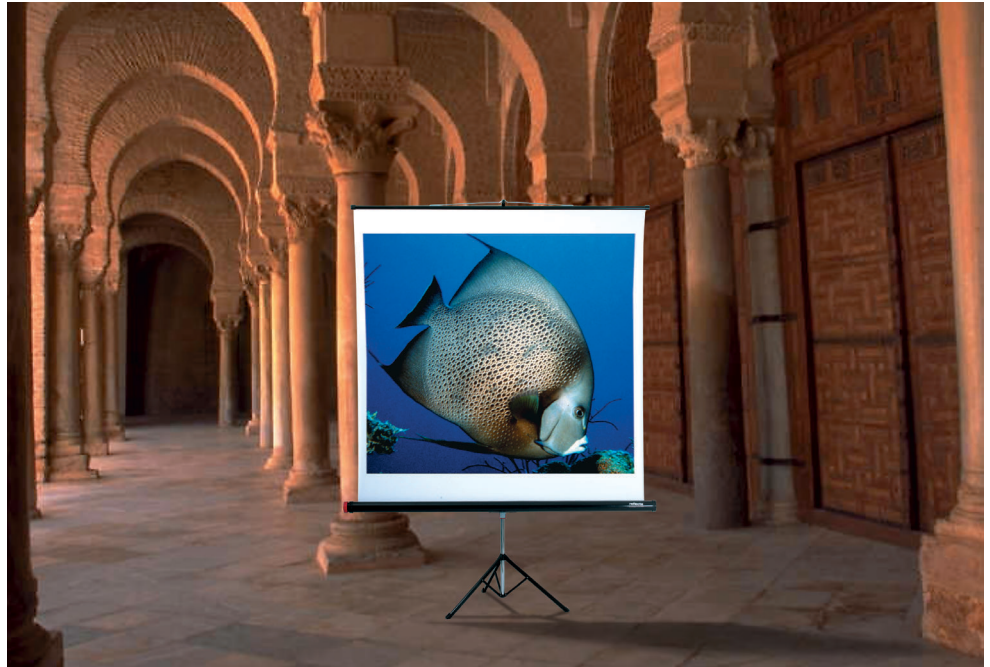

Fitting carrying bags available for all tripod projection screens.

Carrying bags for projection screens

50610	125 x 125 cm
50611	155 x 155 cm
50612	180 x 180 cm
50613	200 x 200 cm
50614	260 cm

Tripod projection screens Alpha – Technical data (all dimensions in cm)

Ref. no	Type	Fabric	Format	A	B	E	F	G	H	Weight
40511	Tripod 125x125	AlphaLux	1:1	125	125	140	6	6	170-205	3 kg
40521	Tripod 155x155	AlphaLux	1:1	155	155	170	6	6	195-245	6 kg
40531	Tripod 180x180	AlphaLux	1:1	180	180	195	6	6	230-280	7 kg
40924	Tripod 125x125	Twinlux	1:1	125	125	140	6	6	170-205	5 kg
40934	Tripod 155x155	Twinlux	1:1	155	155	170	6	6	195-245	6 kg
40944	Tripod 180x180	Twinlux	1:1	180	180	195	6	6	230-280	7 kg

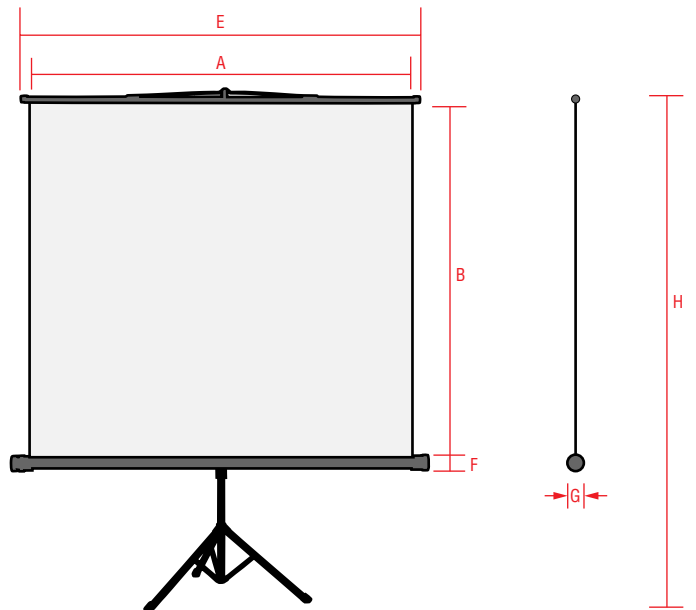

Tensioning knob



Handle



Tripod CrystalLine

The new reflecta CrystalLine Tripods are characterized by the very good Price/Performance ratio. The tripod and tube colour is totally black which looks very modern and can be used for Home Cinema. The high quality fabric gives a brilliant image to the viewer.

Product details:

- Black metal tube, 6 cm diameter.
- Ergonomically designed carrying handle with lock.
- Continuously adjustable height of horizontal tube and telescopic tube.
- Projection screen can be rotated by 360°.
- Integrated keystone eliminator to incline the screen.
- Projection screen in BetaLux, matte white, 1.0 gain and wide viewing angle.
- Light-proof black rear side.
- Continuous black border.
- Optional carrying bags available for all sizes.

Tripod CrystalLine – Technical data (all dimensions in cm)

Ref.No.	Type	Fabric	Format	A	B	C	D	R1	R2	R3	E	F	G	H max.	H min.	Weight
87654	CrystalLine	BetaLux	1:1	125	125	121	121	2	2	2	129	6	6	193	168	8 kg
87650	CrystalLine	BetaLux	1:1	160	160	156	156	2	2	2	164	6	6	247	203	9 kg
87651	CrystalLine	BetaLux	1:1	180	180	176	176	2	2	2	184	6	6	268	223	10 kg
87652	CrystalLine	BetaLux	1:1	200	200	196	196	2	2	2	204	7	7	288	243	12 kg
87653	CrystalLine	BetaLux	1:1	240	240	236	236	2	2	2	244	7	7	308	263	13 kg

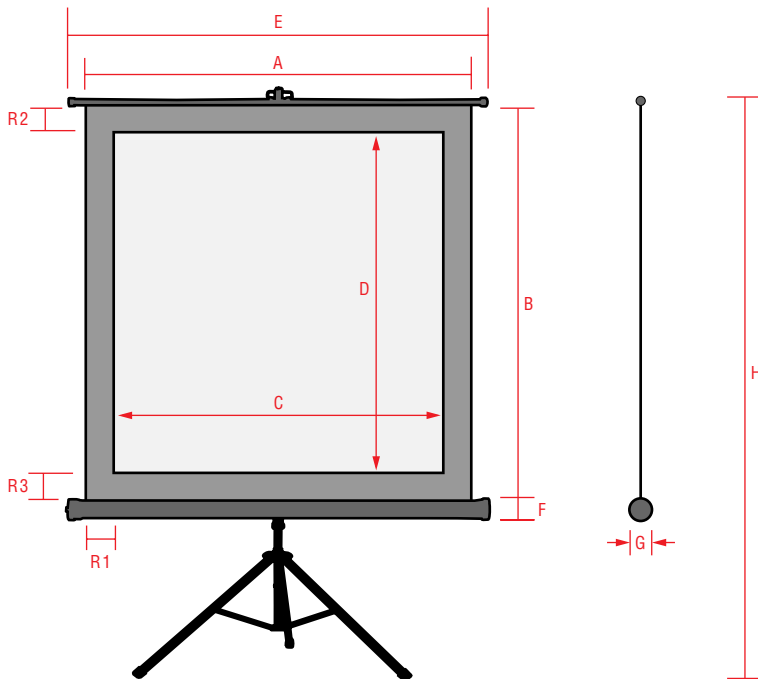

Fitting carrying bags available for all tripod projection screens.

Carrying bags for projection screens

50610	125 x 125 cm
50611	155 x 155 cm
50612	180 x 180 cm
50613	200 x 200 cm
50614	260 cm



Keystone eliminator

Tripod Silverline in large format

High-quality projection screen for professional use. The screen was designed to meet very high demands regarding stableness, stability and safety. Special emphasis was given to secure and comfortable operation as well as easy handling.

Product details:

- Anodized aluminum tube in elegant design, 7 cm x 7 cm.
- High-quality tripod with anti-skid plastic caps on legs for a safe stand.
- Ergonomically designed handle with lock in sturdy plastic.
- Perfectly plain position of the screen due to automatic tensioning.
- Continuously adjustable height of horizontal tube and telescopic tube.
- Projection screen can be rotated vertically by 360° degrees.
- Large extendable overhead keystone eliminator in the tripod head to incline the screen for a correct display of vertical lines.
- Screen lock for easy and safe transportation.
- Ergonomically designed operating elements.
- High-quality UltraLux fabric with 1.2 gain.
- Optional carrying bags for all sizes.



Tripod projection screens Large format – Technical data (all dimensions in cm)

Ref. no.	Type	Fabric	Format	A	B	E	F	G	H	Weight
84031	Tripod LF Pro 180x180	UltraLux	1:1	180	180	196	7.5	7.5	260	10 kg
84051	Tripod LF Pro 200x200	UltraLux	1:1	200	200	216	7.5	7.5	280	12 kg
84071	Tripod LF Pro 240x180	UltraLux	4:3	240	180	256	7.5	7.5	260	14 kg



Fitting carrying bags available for all tripod projection screens.

Carrying bags for projection screens

50613	200 x 200 cm
50614	260 cm

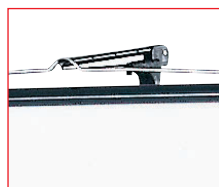
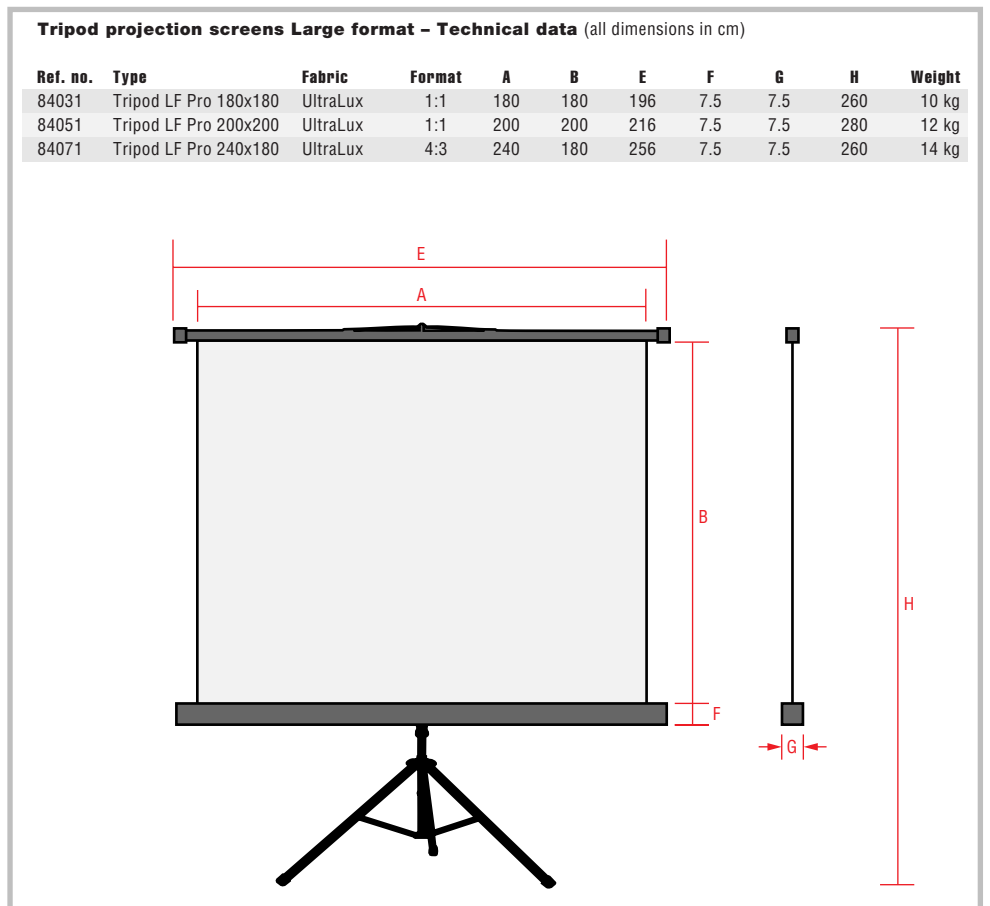

Keystone eliminator



Stable tripod



Lock knob with fixing button and unlock lever



Handle

CINEMOBIL

Portable projection screen in an appealing design for all projection types.

To be installed on the floor or on a table.

Projection screen with black border in 1:1 or 4:3 format with light-proof rear side is available in various sizes.



Cinemobil – Technical data (all dimensions in cm)

Ref. no.	Type	Fabric	Format	A	B	C	D	R1	R2	R3	E	F	G	H	J	Weight
84214	Cinemobil 120x90	AlphaLux	4:3	124	143	120	90	2	2	51	134	8,5	24,5	153	132	9,5 kg

Product details:

- V-shaped tube in elegant design with integrated carrying handle.
- Easy and fast installing and removing.
- Particularly suited for mobile use since the fabric is perfectly protected when retracted in the casing.
- Very plain position due to tensioning mechanism (sturdy roll-up mechanism).
- Continuously adjustable and easy-to-operate telescopic tripod. It can be locked at the bottom side for an easy transportation.
- Continuous black border for improved picture framing.
- Light-proof rear coating for use even in front of a window.
- High-quality AlphaLux fabric with a large viewing angle.

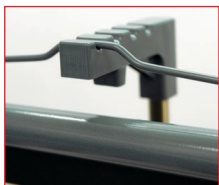
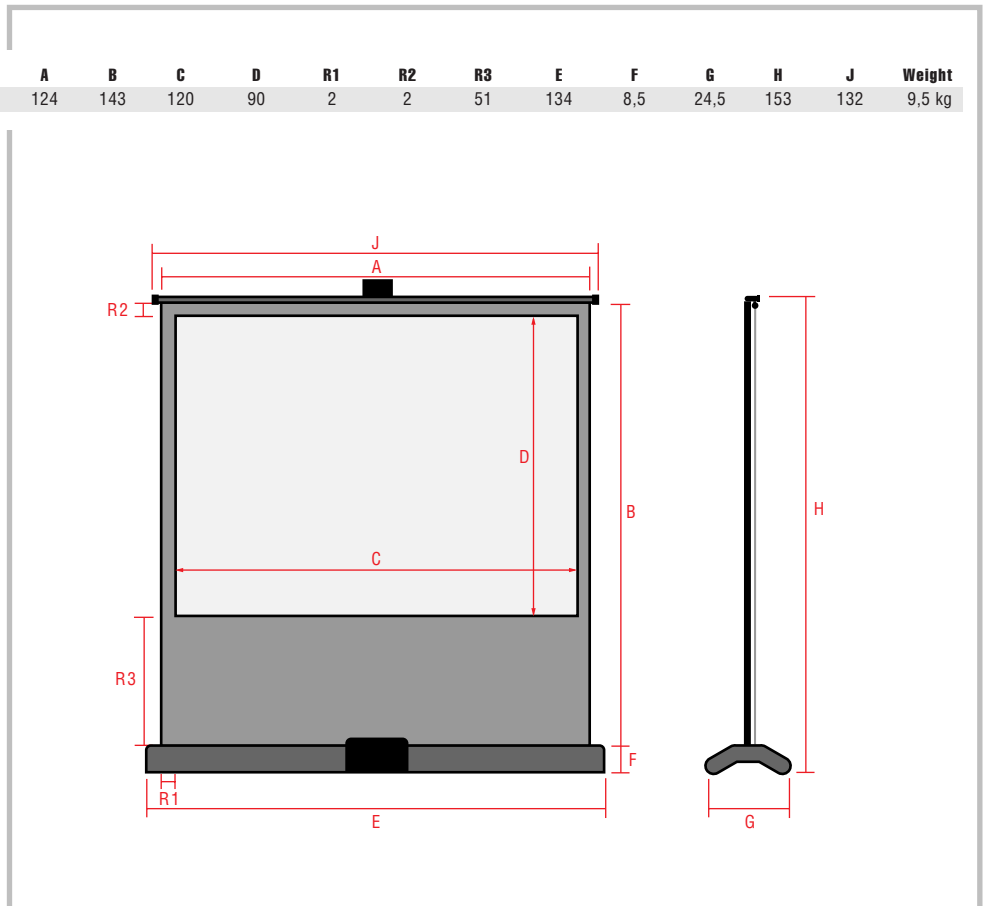

Keystone eliminator



Collar for tripod tube



Retracted screen

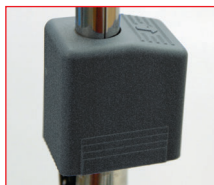

Lock head



Retracting mechanism



Clip to attach the tripod tube to the casing bottom

Ultra-portable table screen

Projection screen to be set up fast and easily. Particularly suitable for flexible and fast projections in the office or for a fast viewing at home.

Product details:

- Mobile and immediately at disposal.
- Fast and simple setting up.
- Sturdy casing to protect against dust and dirt.
- Fold-out legs for a secure stand.
- Ideal for a small group of viewers



Ultra-portable table screen – Technical data (all dimensions in cm)

Ref. no.	Type	Fabric	Format	A	B	C	D	R1	R2	R3	E	F	G	H	Weight
40761	Table screen	GammaLux	4:3	87	77	81	61	3	1	15	96	8	6	95	3 kg

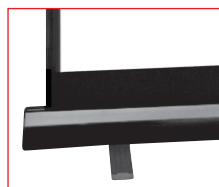
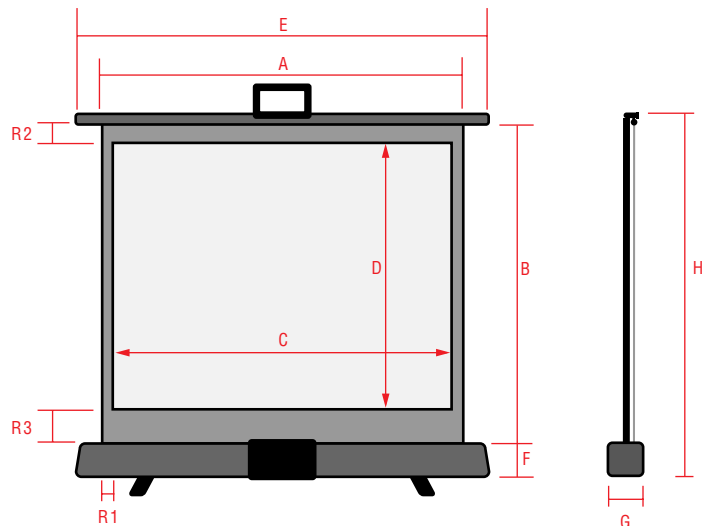

Fold-out legs



Compact design



Handle



Portable floor screen

Stable, compact 4:3 mobile screen for a fast setting up on the floor or table. The screen is simply pulled out from the bottom casing and hooked to a mounting rod which was folded out beforehand. Can be adjusted to different heights. The screen has a 1.5 cm wide black border for clean masking and to increase the perceived contrast of the image. Fabric-based matte white projection screen with black rear side. Viewing angle is 160°.

Product details:

- Integrated carrying handle.
- Space-saving storing.
- Excellent image position.

Portable floor screen - Technical data (all dimensions in cm)

Ref. no.	Type	Fabric	Format	A	B	C	D	R1	R2	R3	E	F	G	H	Weight
40763	Portable floor screen	GammaLux	4:3	128	164	122	91	3	2,5	70	138	8	6	179	4,6
40765	Portable floor screen	GammaLux	4:3	178	211	171	128	3,5	2,5	80	187	8	6	226	6,2
40766	Portable floor screen	GammaLux	4:3	210	225	203	152	3,5	2,5	70	220	8	6	239	7,2

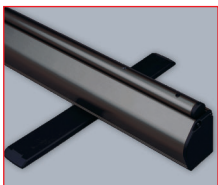
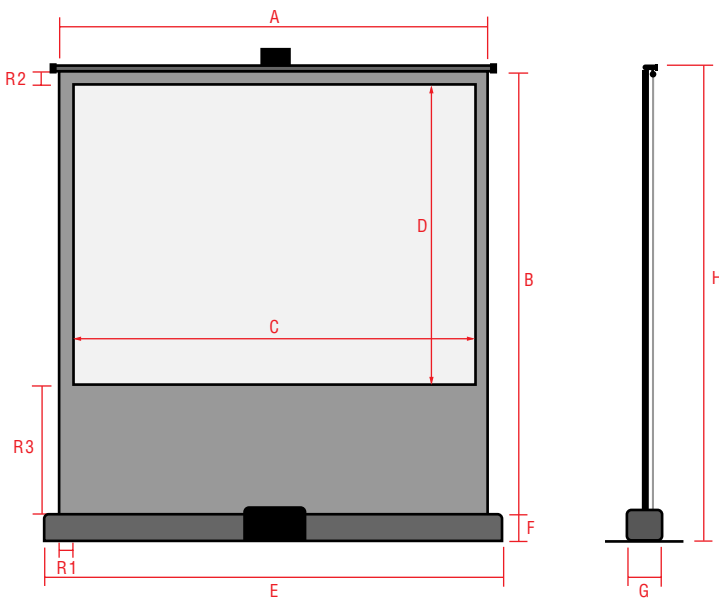

Fold-out legs



Handle



Retracted screen with fixed tripod tube

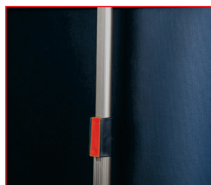

Lock head



Projection screen in landscape format

A high-quality fabric with a wide viewing angle is used for this handy projection screen simply hung to a hook. When rolled up, the landscape projection screen can be stored at a small space. When rolled out, it can be hung everywhere. These are the advantages which will be decisive wherever cost-effective and flexible projections are required. With a total width of four metres, the projection surface of the screen is 12 m².

Product details:

- Projection screen in UltraLux, matte white, 1.2 gain.
- Easy-to-care screen for everyday use for fast and mobile applications.

Landscape format – Technical data (all dimensions in cm)

Ref.No.	Type	Fabric	Format	A	B	G	C	Weight kg
40191	Landscape format 155x155	UltraLux	1:1	155	155	2	163	3 kg
40211	Landscape format 180x180	UltraLux	1:1	180	180	2	188	4 kg
40221	Landscape format 200x200	UltraLux	1:1	200	200	2	208	5 kg
40261	Landscape format 240x180	UltraLux	4:3	240	180	2	248	7 kg
40251	Landscape format 250x190	UltraLux	4:3	250	190	2	258	8 kg
40271	Landscape format 260x195	UltraLux	4:3	260	195	2	268	8 kg
40281	Landscape format 280x210	UltraLux	4:3	280	210	2	288	9 kg
40231	Landscape format 300x240	UltraLux	5:4	300	240	2	308	10 kg
40241	Landscape format 350x262	UltraLux	4:3	350	262	2	358	12 kg
40291	Landscape format 400x300	UltraLux	4:3	400	300	2	408	14 kg

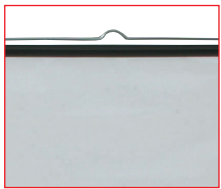
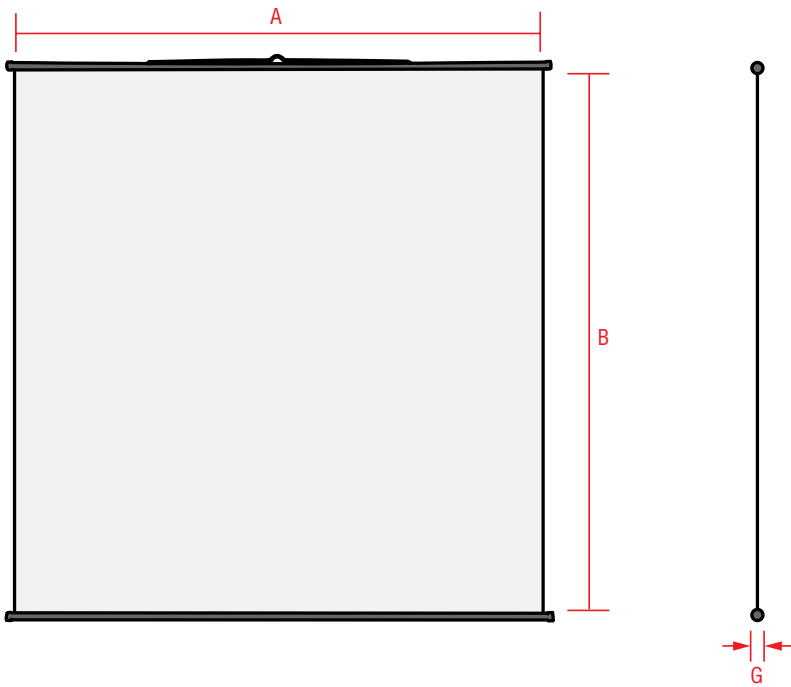

Screen suspension bracket



Weigh-down rod



Aluminum Frame QuickSet

The new, professional and mobile reflecta Quick-Set Aluminium Screen for all kind of Projection (Slide-, Video- or Dataprojection) – Ideal for Events! The QuickSet Screen ensures quick assembling or disassembly. The high quality fabric with reinforced borders is tightened onto the frame with push-buttons and available for Front- or Rearprojection.

The elastic fabric is tightened onto the frame and enables a flush screen surface with black borders for exact Images. Supplied with a very sturdy carrying box with transport wheels.

Product details:

- Complete System with Frontprojection Fabric
- Foldable System for AluminiumFrame
- Easy and Quick Assembling
- High Quality Fabric with reinforced borders and push-buttons
- Excellent Price-/Performance Ratio
- Mobile Use for Events
- Sturdy carrying box with transport wheels



Screen is attached with push buttons

Aluminum frame projection screen Quick Set – Technical data (all dimensions in cm)

Art.No.	Type	Fabric	Format	A	B	C	D	R1	R2	R3	H max.	Weight
86600	QuickSet FP	UltraLux mobil FP	4:3	262	201	244	183	9	9	9	296	19 kg
86601	QuickSet FP	UltraLux mobil FP	4:3	325	249	305	229	10	10	10	359	22 kg
86602	QuickSet FP	UltraLux mobil FP	4:3	386	294	366	274	10	10	10	415	25 kg
86603	QuickSet FP	UltraLux mobil FP	4:3	423	325	405	305	9	10	10	431	28 kg
86604	QuickSet FP	UltraLux mobil FP	4:3	530	403	508	381	11	11	11	551	32 kg
86610	QuickSet FP	UltraLux mobil FP	16:9	287	170	266	149	10	10	10	377	27 kg
86611	QuickSet FP	UltraLux mobil FP	16:9	345	203	325	183	10	10	10	394	32 kg
86612	QuickSet FP	UltraLux mobil FP	16:9	390	229	370	208	10	10	10	456	35 kg
86613	QuickSet FP	UltraLux mobil FP	16:9	423	247	403	227	10	10	10	455	36 kg
86614	QuickSet FP	UltraLux mobil FP	16:9	503	284	487	274	12	12	12	475	54 kg

optional

Art.No.	Type	Fabric	Format	Fabric weight
86650	Single Rearprojection fabric for 86600	UltraLux mobil Rearprojection	4:3	340 g/m ²
86651	Single Rearprojection fabric for 86601	UltraLux mobil Rearprojection	4:3	340 g/m ²
86652	Single Rearprojection fabric for 86602	UltraLux mobil Rearprojection	4:3	340 g/m ²
86653	Single Rearprojection fabric for 86603	UltraLux mobil Rearprojection	4:3	340 g/m ²
86654	Single Rearprojection fabric for 86604	UltraLux mobil Rearprojection	4:3	340 g/m ²
86660	Single Rearprojection fabric for 86610	Ultralux Mobil Rearprojection	16:9	340 g/m ²
86661	Single Rearprojection fabric for 86611	Ultralux Mobil Rearprojection	16:9	340 g/m ²
86662	Single Rearprojection fabric for 86612	Ultralux Mobil Rearprojection	16:9	340 g/m ²
86663	Single Rearprojection fabric for 86613	Ultralux Mobil Rearprojection	16:9	340 g/m ²
86664	Single Rearprojection fabric for 86614	Ultralux Mobil Rearprojection	16:9	340 g/m ²

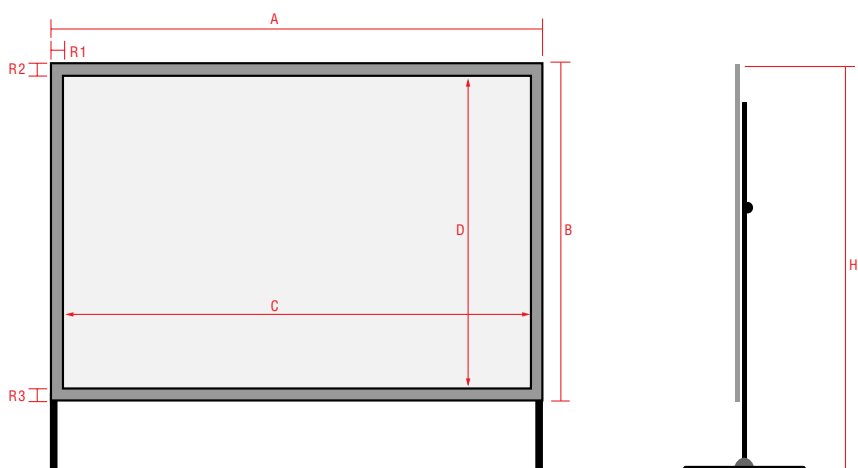
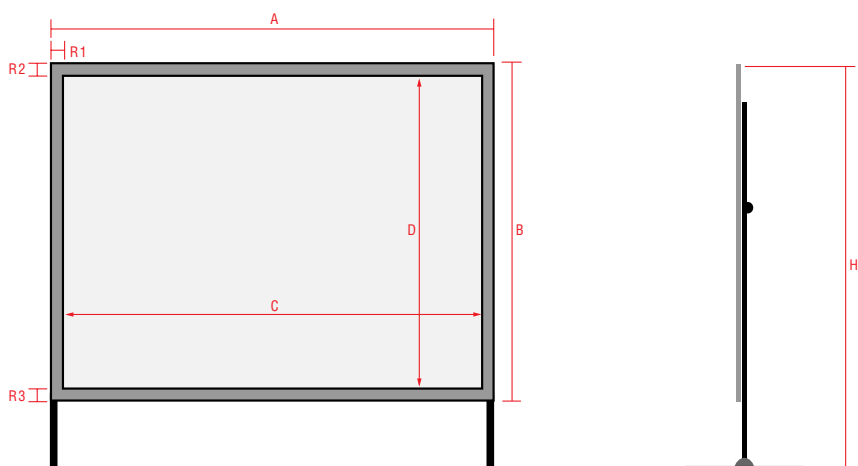

Other systems, sizes and formats on request.

Spring roller

The proven and reliable reflecta spring roller system offers high functionality at a reasonable price.

The screen tube is safely mounted to a wall. The tensioning system guarantees a plain screen.

Product details:

- Fixed projection screen, tube diameter 6 cm.
- Black steel screen case.
- Projection screen attaches safely.
- Spring roller system for perfectly plain projection screen.
- Projection screen with high luminance and large viewing angle.
- Suitable for all common front projection types.

New for spring roller:

- Stop or self-locking roller mechanism.
- Can be mounted to ceiling.



Spring roller – Technical data (all dimensions in cm)

Art.No.	Type	Fabric	Format	A	B	E	G	J	Weight
40821	Spring roller 125x125	AlphaLux	1:1	125	125	138	6	130	4 kg
40822	Spring roller 155x155	AlphaLux	1:1	155	155	167	6	157	5 kg
40823	Spring roller 180x180	AlphaLux	1:1	180	180	194	6	184	6 kg

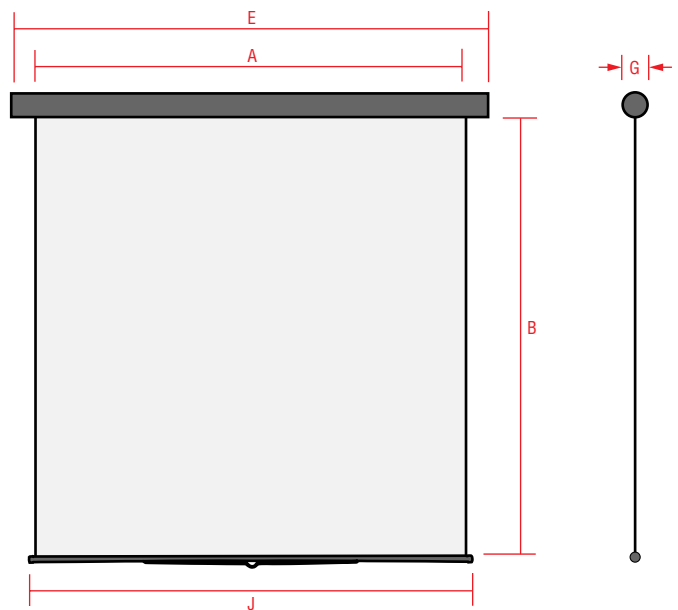

Wall mount of tube



Screen suspension bracket



Galaxy self-locking roller

The retractable reflecta projection screen is installed in a profiled sheetmetal case and is operated with the locking mechanism with the soft lift function. When pulled slightly downwards, the projection screen automatically retracts slowly and safely to the tube. A soft brake avoids a fast and uncontrolled retracting. The screen can be stopped at any intermediate height to adjust to the various projection formats. With the light-proof rear coating, it can be used even in front of a window. The black border makes the screen particularly suited for home theatres.

Product details:

- Mounted to wall or ceiling.
- Simple installation and easy handling due to retracting mechanism with soft lift feature.
- Light-proof black rear side.
- Black masking.
- Very concise tube allows for space-saving installation.
- Large viewing angle.
- Suitable for all common front projection types.
- High-quality DeltaLux fabric with 1.0 gain.

Galaxy self-locking roller - Technical data (all dimensions in cm)

Ref. no.	Type	Fabric	Format	A	B	C	D	R1	R2	R3	E	F	G	J	Weight
85911	Galaxy locking	DeltaLux	1:1	183	190	178	178	2,3	8	3,5	190	8,7	8,1	186	10 kg
85921	Galaxy locking	DeltaLux	1:1	213	215	203	203	5	8	4	220,4	8,7	8,1	216	13 kg
85914	Galaxy locking	DeltaLux	4:3	179	162	171	128	4	30	3,5	186,4	8,7	8,1	182	9 kg
85924	Galaxy locking	DeltaLux	4:3	213	186	203	152	5	30	4	220,4	8,7	8,1	216	12 kg
85944	Galaxy locking	DeltaLux	4:3	243	210	234	176	4,7	30	4	250,9	10,3	9,2	246	18 kg
85915	Galaxy locking	DeltaLux	16:9	176	149	170	96	3	50	3,5	183,8	8,7	8,1	179	9 kg
85925	Galaxy locking	DeltaLux	16:9	213	169	203	115	5	50	4,5	220,4	8,7	8,1	216	12 kg
85935	Galaxy locking	DeltaLux	16:9	231	179	221	125	5	50	4	238,8	8,7	8,1	234	17 kg
85945	Galaxy locking	DeltaLux	16:9	243	186	234	132	4,7	50	4	250,9	10,3	9,2	247	18 kg

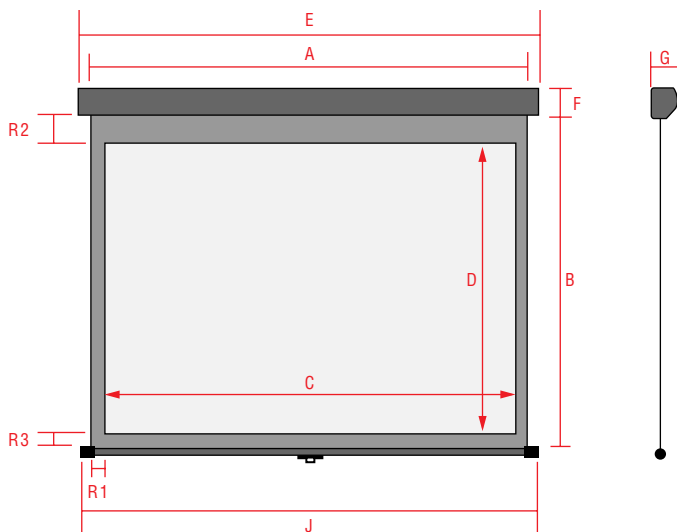

Mounting material

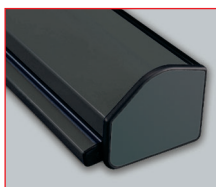

Retracted screen



Stable solid metal tube

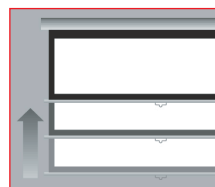

Soft lift function



**CrystalLine Self-locking roller/
Self-locking roller Softlift/Electric**

The new reflecta CrystalLine self-locking roller and electric projection screens are extremely good value for money. The well-engineered self-locking roller and electric mechanism with remote control (only with CrystalLine electric) allows for an easy and silent extending and retracting of the projection screen. The high-grade screen fabric delivers brilliant images with any type of projection. The CrystalLine electric projection screens include a remote control.

Product details:

- Mounted to wall or ceiling.
- Simple installation and easy handling.
- Large viewing angle.
- Suitable for all common front projection types.
- High-quality screen BetaLux with 1.0 gain.
- Light-proof rear with black coating.
- Black border.
- Remote control included (only with electric variant).



Radio remote control (only for electric variant)

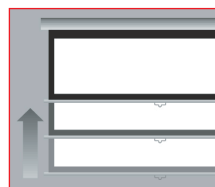

Softlift-function (only with CrystalLine self-locking roller Softlift)

CrystalLine Self-locking roller/Self-locking roller Softlift/Electric – Technical data (all dimensions in cm)

Art.No.	Type	Fabric	Format	A	B	C	D	R1	R2	R3	E	F	G	J	Weight
87660	CrystalLine self-locking roller	BetaLux	1:1	160	160	156	156	2	2	2	175	6,8	6,8	165	6 kg
87661	CrystalLine self-locking roller	BetaLux	1:1	180	180	176	176	2	2	2	195	6,8	6,8	185	7 kg
87662	CrystalLine self-locking roller	BetaLux	1:1	200	200	196	196	2	2	2	215	6,8	6,8	205	9 kg
87663	CrystalLine self-locking roller	BetaLux	1:1	240	240	236	236	2	2	2	255	6,8	6,8	245	13 kg
87664	CrystalLine self-locking roller	BetaLux	1:1	300	300	292	292	4	4	4	315	8,9	8,9	305	16 kg
87685	CrystalLine self-locking roller	BetaLux	4:3	160	129	156	117	2	10	2	175	6,8	6,8	165	6 kg
87680	CrystalLine self-locking roller	BetaLux	4:3	180	144	176	132	2	10	2	195	6,8	6,8	185	7 kg
87681	CrystalLine self-locking roller	BetaLux	4:3	200	159	196	147	2	10	2	215	6,8	6,8	205	9 kg
87682	CrystalLine self-locking roller	BetaLux	4:3	220	174	216	162	2	10	2	235	6,8	6,8	225	10 kg
87683	CrystalLine self-locking roller	BetaLux	4:3	240	189	236	177	2	10	2	255	6,8	6,8	245	11 kg
87684	CrystalLine self-locking roller	BetaLux	4:3	300	233	292	219	4	10	4	315	8,9	8,9	305	16 kg
87700	CrystalLine self-locking roller	BetaLux	16:9	160	130	156	88	2	40	2	175	6,8	6,8	165	6 kg
87701	CrystalLine self-locking roller	BetaLux	16:9	180	141	176	99	2	40	2	195	6,8	6,8	185	7 kg
87702	CrystalLine self-locking roller	BetaLux	16:9	200	152	196	110	2	40	2	215	6,8	6,8	205	8 kg
87703	CrystalLine self-locking roller	BetaLux	16:9	240	175	236	133	2	40	2	255	6,8	6,8	245	10 kg
87704	CrystalLine self-locking roller	BetaLux	16:9	300	208	292	164	4	40	4	315	8,9	8,9	305	16 kg
87720	CrystalLine self-locking roller Softlift	BetaLux	1:1	160	160	156	156	2	2	2	175	6,8	6,8	165	6 kg
87721	CrystalLine self-locking roller Softlift	BetaLux	1:1	180	180	176	176	2	2	2	195	6,8	6,8	185	7 kg
87722	CrystalLine self-locking roller Softlift	BetaLux	1:1	200	200	196	196	2	2	2	215	6,8	6,8	205	9 kg
87723	CrystalLine self-locking roller Softlift	BetaLux	1:1	240	240	236	236	2	2	2	255	6,8	6,8	245	13 kg
87730	CrystalLine self-locking roller Softlift	BetaLux	4:3	180	144	176	132	2	10	2	195	6,8	6,8	185	7 kg
87731	CrystalLine self-locking roller Softlift	BetaLux	4:3	200	159	196	147	2	10	2	215	6,8	6,8	205	9 kg
87732	CrystalLine self-locking roller Softlift	BetaLux	4:3	220	174	216	162	2	10	2	235	6,8	6,8	225	10 kg
87670	CrystalLine Electric	BetaLux	1:1	160	160	156	156	2	2	2	187	8,9	8,9	165	9 kg
87671	CrystalLine Electric	BetaLux	1:1	180	180	176	176	2	2	2	207	8,9	8,9	185	11 kg
87672	CrystalLine Electric	BetaLux	1:1	200	200	196	196	2	2	2	227	8,9	8,9	205	13 kg
87673	CrystalLine Electric	BetaLux	1:1	240	240	236	236	2	2	2	267	8,9	8,9	245	15 kg
87674	CrystalLine Electric	BetaLux	1:1	300	300	292	292	4	4	4	327	8,9	8,9	305	24 kg
87690	CrystalLine Electric	BetaLux	4:3	160	129	156	117	2	10	2	187	8,9	8,9	165	9 kg
87691	CrystalLine Electric	BetaLux	4:3	180	144	176	132	2	10	2	207	8,9	8,9	185	10 kg
87692	CrystalLine Electric	BetaLux	4:3	200	159	196	147	2	10	2	227	8,9	8,9	205	13 kg
87693	CrystalLine Electric	BetaLux	4:3	240	189	236	177	2	10	2	267	8,9	8,9	245	15 kg
87694	CrystalLine Electric	BetaLux	4:3	300	233	292	219	4	10	4	327	8,9	8,9	305	24 kg
87710	CrystalLine Electric	BetaLux	16:9	160	130	156	88	2	40	2	187	8,9	8,9	165	9 kg
87711	CrystalLine Electric	BetaLux	16:9	180	141	176	99	2	40	2	207	8,9	8,9	185	10 kg
87712	CrystalLine Electric	BetaLux	16:9	200	152	196	110	2	40	2	227	8,9	8,9	205	13 kg
87713	CrystalLine Electric	BetaLux	16:9	240	175	236	133	2	40	2	267	8,9	8,9	245	15 kg
87714	CrystalLine Electric	BetaLux	16:9	300	208	292	164	4	40	4	327	8,9	8,9	305	24 kg

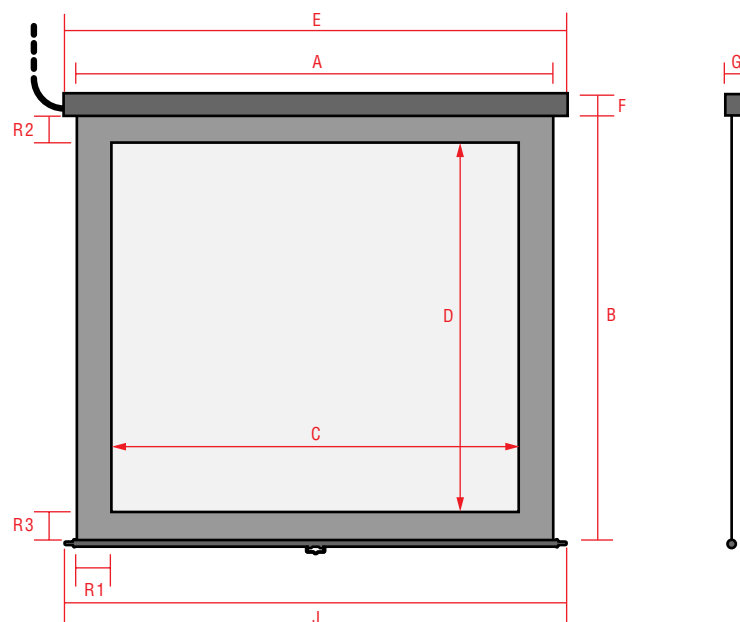

Silverline self-locking roller / Electric

The reflecta large projection screen to be fixed permanently to a wall or ceiling is mounted to an aluminum profile case and is operated either manually or motor-driven. The projection screen is extended and retracted with a space-saving and silent tube motor with integrated end position switch. With the switch, the screen can be stopped at any desired position. Optionally, the screen can be equipped with a locking mechanism to stop the screen at intermediate heights to adjust to different projection formats. Ideal for the training and communications sector.

Product details:

- Mounted to wall or ceiling.
- Electric or manual operation.
- Simple installation and easy handling.
- 8.5 cm x 8.5 cm large tube allows for space-saving installation.
- Large viewing angle.
- Suitable for all common front projection types.
- High-quality screens available in UltraLux (1.2 gain) or RearPro (1.6 gain) quality.

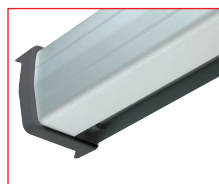
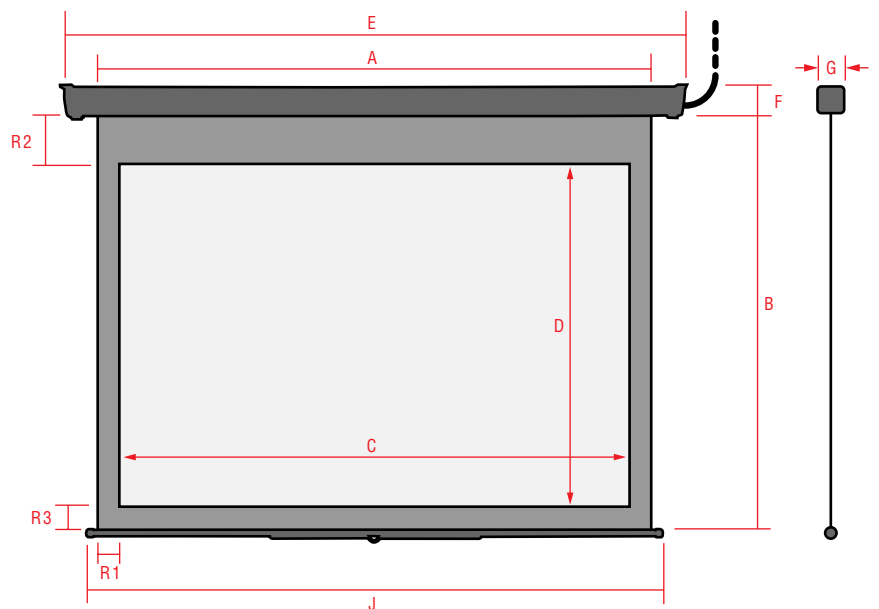

Solid aluminum tube



Plastic end caps for wall or ceiling installation

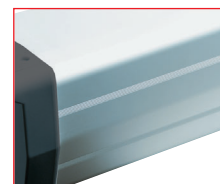

Warp-resistant profile



Switch of the electric Silverline

Silverline self-locking roller – Technical data (all dimensions in cm)

Art.No.	Type	Fabric	Format	A	B	C	D	R1	R2	R3	E	F	G	J	Weight
80900	SilverLine self-locking roller	UltraLux	1:1	155	160	155	160				173	8,5	8,5	162	5 kg
80910	SilverLine self-locking roller	UltraLux	1:1	180	190	180	190				198	8,5	8,5	187	6 kg
80920	SilverLine self-locking roller	UltraLux	1:1	200	210	200	210				218	8,5	8,5	207	7 kg
80930	SilverLine self-locking roller	UltraLux	4:3	220	180	220	180				238	8,5	8,5	227	8 kg
80940	SilverLine self-locking roller	UltraLux	4:3	240	180	240	180				258	8,5	8,5	247	9 kg
80904	SilverLine self-locking roller	UltraLux	4:3	155	149	145	109	5	35	5	173	8,5	8,5	162	5 kg
80914	SilverLine self-locking roller	UltraLux	4:3	180	168	170	128	5	35	5	198	8,5	8,5	187	6 kg
80924	SilverLine self-locking roller	UltraLux	4:3	200	183	190	143	5	35	5	218	8,5	8,5	207	7 kg
80934	SilverLine self-locking roller	UltraLux	4:3	220	193	210	158	5	35	5	238	8,5	8,5	227	8 kg
80944	SilverLine self-locking roller	UltraLux	4:3	240	213	230	173	5	35	5	258	8,5	8,5	247	9 kg
80954	SilverLine self-locking roller	UltraLux	4:3	280	233	270	203	5	25	5	298	8,5	8,5	287	12 kg
80905	SilverLine self-locking roller	UltraLux	16:9	155	132	145	82	5	45	5	173	8,5	8,5	162	5 kg
80915	SilverLine self-locking roller	UltraLux	16:9	180	146	170	96	5	45	5	198	8,5	8,5	187	6 kg
80925	SilverLine self-locking roller	UltraLux	16:9	200	157	190	107	5	45	5	218	8,5	8,5	207	7 kg
80935	SilverLine self-locking roller	UltraLux	16:9	220	168	210	118	5	45	5	238	8,5	8,5	227	8 kg
80945	SilverLine self-locking roller	UltraLux	16:9	240	179	230	129	5	45	5	258	8,5	8,5	247	9 kg
80955	SilverLine self-locking roller	UltraLux	16:9	280	197	270	152	5	40	5	298	8,5	8,5	287	12 kg
80916	SilverLine self-locking roller Rear Pro	Rear Pro		180	190	180	190				198	8,5	8,5	187	6 kg
80926	SilverLine self-locking roller Rear Pro	Rear Pro		200	210	200	210				218	8,5	8,5	207	7 kg
80936	SilverLine self-locking roller Rear Pro	Rear Pro		220	200	220	200				238	8,5	8,5	227	8 kg
80946	SilverLine self-locking roller Rear Pro	Rear Pro		240	200	240	200				258	8,5	8,5	247	9 kg

Silverline Electric – Technical data (all dimensions in cm)

Art.No.	Type	Fabric	Format	A	B	C	D	R1	R2	R3	E	F	G	J	Weight
81801	SilverLine Electric professional	Ultralux		180	200	180	200				199	8,5	8,5	187	10 kg
81811	SilverLine Electric professional	Ultralux		200	210	200	210				219	8,5	8,5	207	11 kg
81821	SilverLine Electric professional	Ultralux		220	220	220	220				239	8,5	8,5	227	12 kg
81831	SilverLine Electric professional	Ultralux		240	200	240	200				259	8,5	8,5	247	13 kg
81841	SilverLine Electric professional	Ultralux		300	200	300	200				319	11	10	307	18 kg
81851	SilverLine Electric professional	Ultralux		300	225	300	225				319	11	10	307	20 kg
81861	SilverLine Electric professional	Ultralux		300	250	300	250				319	11	10	307	21 kg
81871	SilverLine Electric professional	Ultralux		300	300	300	300				319	11	10	307	21 kg
81881	SilverLine Electric professional	Ultralux		350	265	350	265				369	11	10	357	22 kg
81891	SilverLine Electric professional	Ultralux		350	300	350	300				369	11	10	357	22 kg
81892	SilverLine Electric professional	Ultralux		350	350	350	350				367	15	14,5	358	37 kg
81804	SilverLine Electric professional	Ultralux	4:3	170	160	160	120	5	35	5	189	8,5	8,5	177	9 kg
81814	SilverLine Electric professional	Ultralux	4:3	180	168	170	128	5	35	5	199	8,5	8,5	187	10 kg
81824	SilverLine Electric professional	Ultralux	4:3	200	183	190	143	5	35	5	219	8,5	8,5	207	11 kg
81834	SilverLine Electric professional	Ultralux	4:3	220	198	210	158	5	35	5	239	8,5	8,5	227	12 kg
81844	SilverLine Electric professional	Ultralux	4:3	240	213	230	173	5	35	5	259	8,5	8,5	247	14 kg
81874	SilverLine Electric professional	Ultralux	4:3	280	233	270	203	5	35	5	299	8,5	8,5	287	17 kg
81854	SilverLine Electric professional	Ultralux	4:3	300	258	290	218	5	35	5	319	11	10	307	21 kg
81864	SilverLine Electric professional	Ultralux	4:3	350	295	340	255	5	35	5	369	11	10	357	22 kg
81805	SilverLine Electric professional	Ultralux	16:9	170	140	160	90	5	45	5	189	8,5	8,5	177	9 kg
81815	SilverLine Electric professional	Ultralux	16:9	180	146	170	96	5	45	5	199	8,5	8,5	187	10 kg
81825	SilverLine Electric professional	Ultralux	16:9	200	157	190	107	5	45	5	219	8,5	8,5	207	11 kg
81835	SilverLine Electric professional	Ultralux	16:9	220	168	210	118	5	45	5	239	8,5	8,5	227	12 kg
81845	SilverLine Electric professional	Ultralux	16:9	240	180	230	130	5	45	5	259	8,5	8,5	247	14 kg
81875	SilverLine Electric professional	Ultralux	16:9	280	197	270	152	5	45	5	299	8,5	8,5	287	17 kg
81855	SilverLine Electric professional	Ultralux	16:9	300	213	290	163	5	45	5	319	11	10	307	22 kg
81865	SilverLine Electric professional	Ultralux	16:9	350	241	340	191	5	45	5	369	11	10	357	22 kg

WhiteLine Motor – Technical data (all dimensions in cm)

Art.No.	Type	Fabric	Format	A	B	C	D	R1	R2	R3	E	F	G	J	Weight
81893	WhiteLine Electric professional	Ultralux		400	350	400	350				423	18	18,5	408	45 kg
81894	WhiteLine Electric professional	Ultralux		400	400	400	400				423	18	18,5	408	47 kg
81895	WhiteLine Electric professional	Ultralux		500	400	500	400				523	18	18,5	508	58 kg
81896	WhiteLine Electric professional	Ultralux		500	500	500	500				523	18	18,5	508	60 kg
81897	WhiteLine Electric professional	Ultralux		600	400	600	400				623	18	18,5	608	65 kg
81900	WhiteLine Electric professional	Ultralux	4:3	400	335	390	295	5	35	5	417	15	14,5	408	42 kg
81901	WhiteLine Electric professional	Ultralux	4:3	500	410	490	370	5	35	5	523	18	18,5	508	57 kg
81902	WhiteLine Electric professional	Ultralux	4:3	600	450	590	442	5	5	5	623	18	18,5	608	70 kg
81906	WhiteLine Electric professional	Ultralux	16:9	400	270	390	220	5	45	5	417	15	14,5	408	42 kg
81907	WhiteLine Electric professional	Ultralux	16:9	500	325	490	275	5	45	5	523	18	18,5	508	57 kg
81908	WhiteLine Electric professional	Ultralux	16:9	600	385	590	335	5	45	5	623	18	18,5	608	63 kg

**Other sizes and formats on request
(also available with rear projection fabric).**



Superior Motor

With great attention to the aesthetic and technological details, reflecta Motor Superior is the electric screen with a low-noise motor guaranteeing maximum reliability. Refined design together with the technological functionality makes reflecta Motor Superior the ideal screen to meet every need of practical use and elegant style.

Product details:

- Radio Controlled Remote-Control included
- Viewing angle 120°
- Thickness 0.40 mm
- Black Border (in formats 4:3 and 16:9)
- Front matte white, rear black
- Gain factor 1.2
- Wall or Ceiling mounting

Other sizes on request



Ceiling mounting

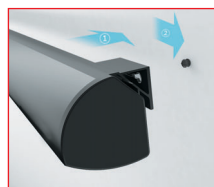

Wall mounting

Superior Motor – Technical data (all dimensions in cm)

Art.No.	Type	Fabric	Format	A	B	C	D	R1	R2	R3	E	F	G	J	Weight
81920	Motor Superior 200x200	UltraLux	1:1	200	200	200	200	0	0	0	213,2	8	8	206,5	12,6 kg
81921	Motor Superior 240x200	UltraLux	1:1	240	200	240	200	0	0	0	255,4	8	8	247,5	14,5 kg
81930	Motor Superior 200x168 (190x143)	UltraLux	4:3	200	168	190	143	5	20	5	213,2	8	8	206,5	12,6 kg
81931	Motor Superior 240x198 (230x173)	UltraLux	4:3	240	198	230	173	5	20	5	255,4	8	8	247,5	14,5 kg
81940	Motor Superior 200x113 (190x107)	UltraLux	16:9	200	113	190	107	5	35	5	213,2	8	8	206,5	12,6 kg
81941	Motor Superior 240x169 (230x129)	UltraLux	16:9	240	169	230	129	5	35	5	255,4	8	8	247,5	14,5 kg

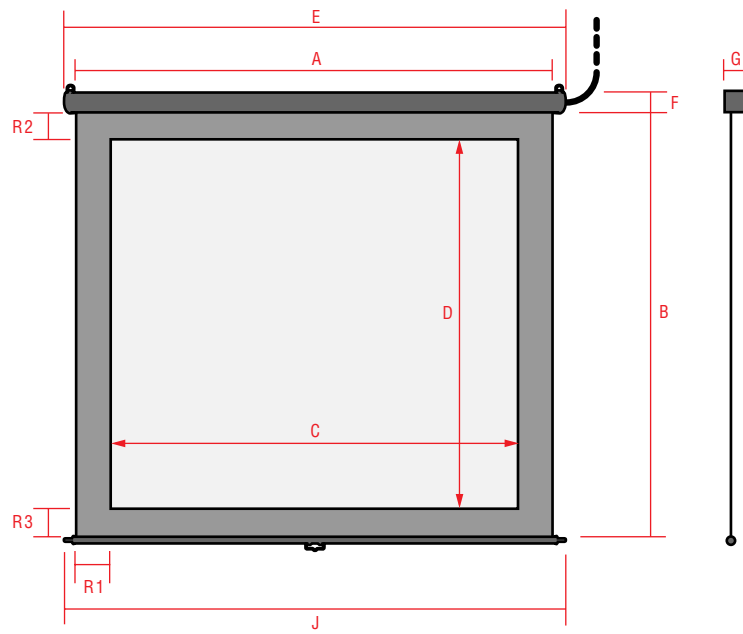



Cosmos N

To be used in conference rooms or in the private home theatre, the electric reflecta Cosmos N screen offers a high-end solution for your projections. The reflecta electric system lives up to highest standards due to the conscious use of sturdy and safe components for a long product life.

Product details:

- Fixed projection screen; with mounting system for an easy installation to the wall or ceiling.
- Available as electric RC Cosmos with RC remote control; switch on request.
- Screens in ValueLux quality (gain 1.2) .
- The screen is rolled up and down via a tube motor installed to the right of the steel shaft to save space and reduce noise. The motor has an integrated end position switch.
- The compact cross-section makes it ideal to be installed in intermediate ceilings or in concise places. Optional installation frame for suspended ceilings available.
- White tube with RAL 9010 powder coating.
- Exactly sized precision steel shaft ensures perfectly plain position and flawless rolling of the screen.
- Flame resistant screen material.
- Screens excel with their colour-neutral imaging.
- Projection screens correspond to the latest safety technology.
- Projection formats 1:1 / 16:9 / 4:3 for all projection types.
- Black rear side for all projection formats.
- Continuous black screen border for masking for the projection formats 16:9 and 4:3.

Special sizes and mounting frames on request



Lowered Screen



Black border

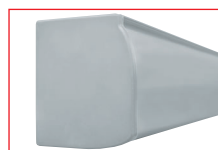

Side view

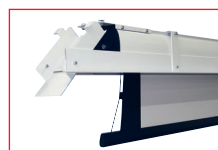

Mounting frame for recessed ceiling

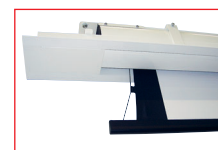

Detail picture of the mounting frame



RC unit of the electric RC Cosmos

Cosmos N – Technical data (all dimensions in cm)

Art.No.	Type	Fabric	Format	A	B	C	D	R1	R2	R3	E	F	G	J	Weight
81100	Cosmos N Motor 180x180	ValueLux	1:1	180	180	180	180	0	0	0	194	10,5	10,5	192	17 kg
81101	Cosmos N Motor 200x200	ValueLux	1:1	200	200	200	200	0	0	0	214	10,5	10,5	212	19 kg
81102	Cosmos N Motor 250x250	ValueLux	1:1	250	250	250	250	0	0	0	264	12,5	12,5	262	38 kg
81103	Cosmos N Motor 300x300	ValueLux	1:1	300	300	300	300	0	0	0	314	12,5	12,5	312	42 kg
81110	Cosmos N Motor 180x134	ValueLux	4:3	180	137	172	129	4	4	5	194	10,5	10,5	192	16,5 kg
81111	Cosmos N Motor 200x152	ValueLux	4:3	200	152	192	144	4	4	5	214	10,5	10,5	212	18,5 kg
81112	Cosmos N Motor 240x182	ValueLux	4:3	240	182	232	174	4	4	5	254	10,5	10,5	252	22,5 kg
81113	Cosmos N Motor 300x227	ValueLux	4:3	300	227	292	219	4	4	5	314	12,5	12,5	312	33,5 kg
81120	Cosmos N Motor 180x131	ValueLux	16:9	180	131	172	97	4	30	5	194	10,5	10,5	192	16 kg
81121	Cosmos N Motor 200x142	ValueLux	16:9	200	142	192	108	4	30	5	214	10,5	10,5	212	18 kg
81122	Cosmos N Motor 300x198	ValueLux	16:9	300	198	292	164	4	30	5	314	12,5	12,5	312	32,5 kg

81385 Mounting frame for 180 – 260 cm + 310 cm Cosmos N

81386 Mounting frame for 300 cm Cosmos N

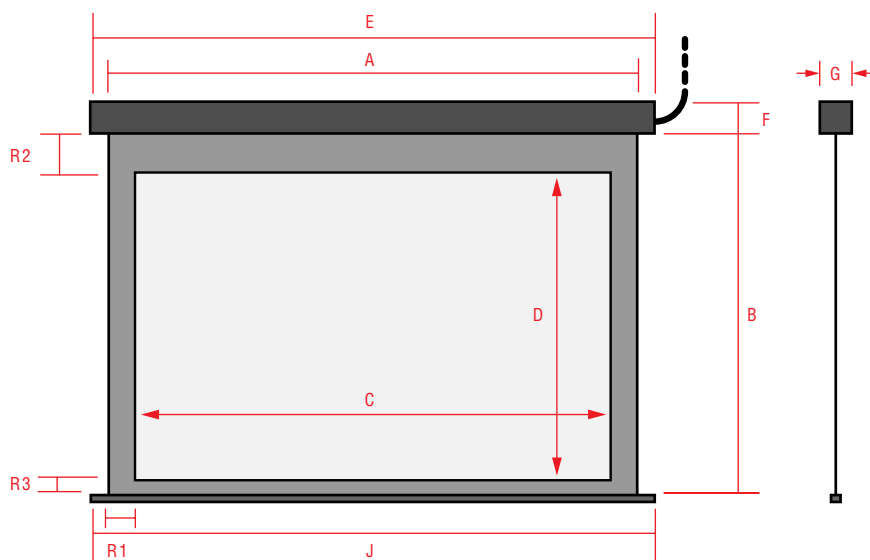



Cinehome

The Cinehome projection screen is a high-end, elegant framed screen with a black aluminum frame. The black colour absorbs light and avoids disturbing reflections. Another detail of the Cinehome framed screen is the high-quality projection fabric which was designed especially for beamer projections. On the rear, the screen has lugs to attach to the aluminum frame. The frame is assembled quickly and is particularly suited to be mounted permanently to a wall.

Product details:

- Black velvet frame.
- Either with front or rear projection material.
- Screen is optimised for beamers.

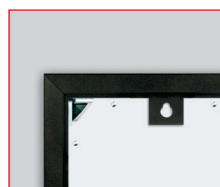

Suspension of Cinehome



High-quality black frame



Stable corner elements

Cinehome - Technical data (all dimensions in cm)

Art.No.	Type	Fabric	Format	C	D	R1	R2	R3	G	Weight
82510	CineHome	Ultralux home	4:3	146	110	6	6	6	3,5	8,5 kg
82511	CineHome	Ultralux home	4:3	171	128	6	6	6	3,5	9,5 kg
82512	CineHome	Ultralux home	4:3	203	152	6	6	6	3,5	11,5 kg
82513	CineHome	Ultralux home	4:3	234	176	6	6	6	3,5	13,5 kg
82514	CineHome	Ultralux home	4:3	305	229	6	6	6	3,5	17 kg
82515	CineHome	Ultralux home	16:9	171	96	6	6	6	3,5	7 kg
82516	CineHome	Ultralux home	16:9	203	115	6	6	6	3,5	10 kg
82517	CineHome	Ultralux home	16:9	221	125	6	6	6	3,5	11 kg
82518	CineHome	Ultralux home	16:9	234	132	6	6	6	3,5	12 kg
82519	CineHome	Ultralux home	16:9	266	150	8	8	8	3,5	13,5 kg
82520	CineHome	Ultralux home	16:9	332	187	6	6	6	3,5	25 kg

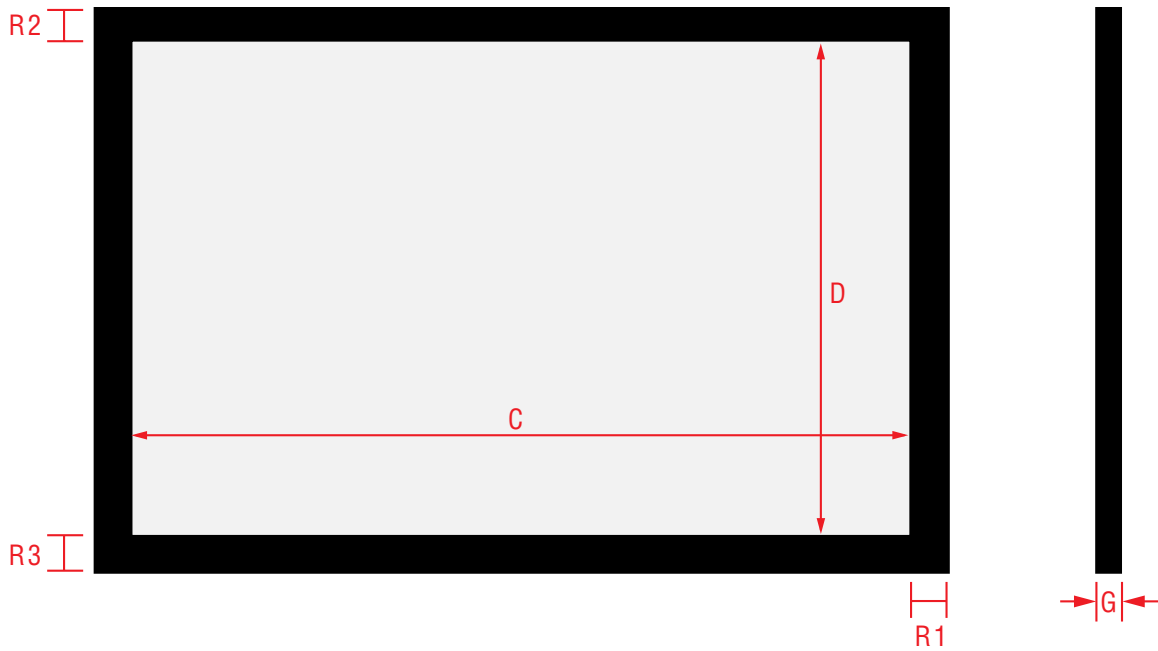



Projection screens to your dimensions...

For special purposes, you will need a special projection screen. If you need a special size, face an unusual installation situation, or want a special colour for the tube – we have an open ear. Just ask us.



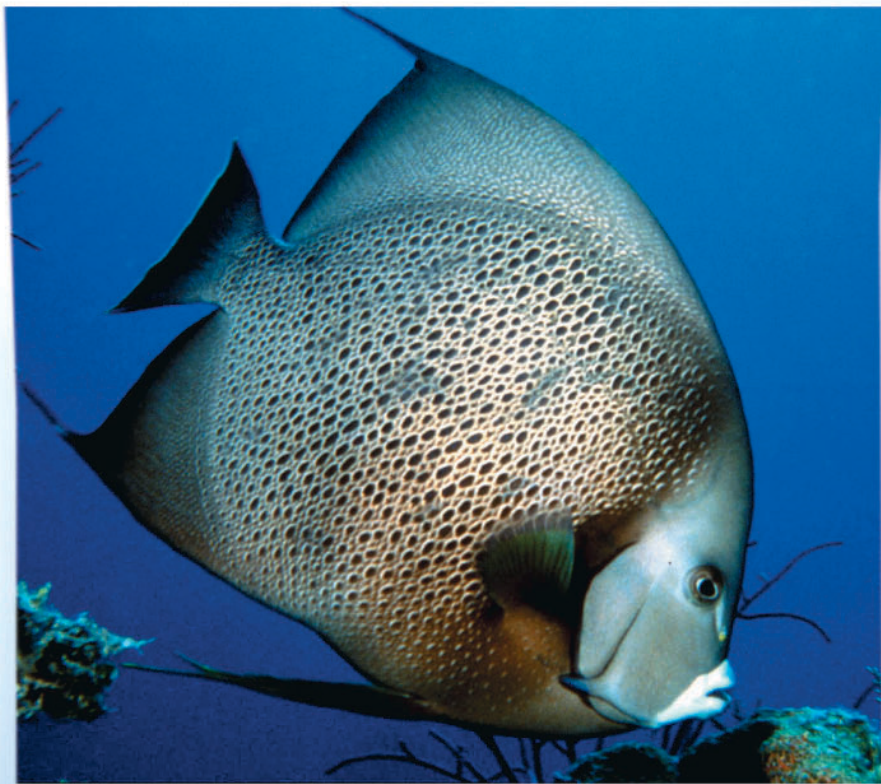

reflecta



There are detailed catalogues of our other products available. Ask for them – we will gladly send them to you.

- Projector and TV-Mounts
- Presentation technique
- Film and slide scanners
- Video lights



4 005039 722080

As part of our continued efforts to improve the quality of our products, we reserve the right to change our products without notification.

Art.-No. 72208, © reflecta Germany / Version 09/16

reflecta®

reflecta GmbH
 Merkurstrasse 8
 D-72184 Eutingen / Germany
 Tel.: +49 (0)74 57/94 65 60
 mail@reflecta.de
 www.reflecta.de