

reflecta gmbh
 Merkurstrasse 8
 72184 Eutingen
 Germany

mail@reflecta.de
 www.reflecta.de

INSTALLATION MANUAL

Video Wall Stand & Cart and Accessories

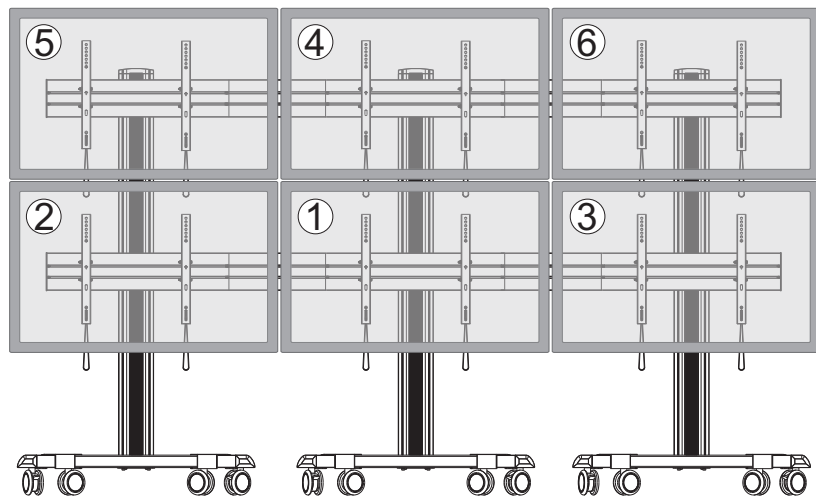

Note: The displays are installed by the numerical order given.

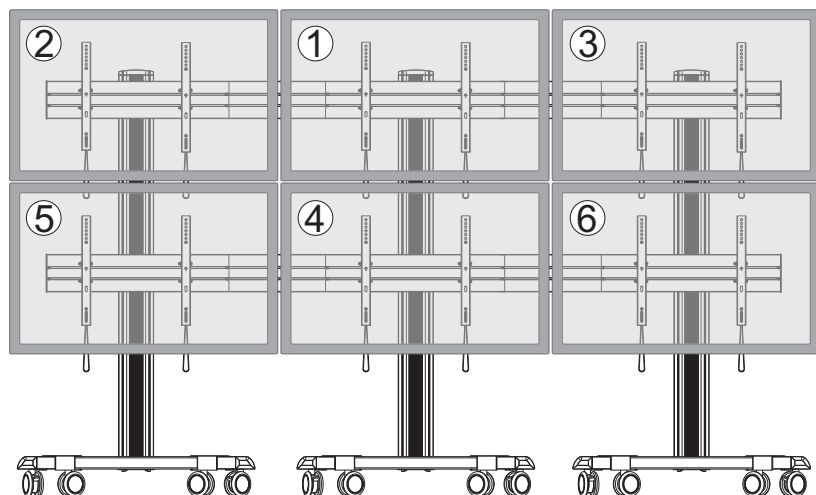

Note: The angle of displays are adjusted by the numerical order given.

Maintenance

- Check that the bracket is secure and safe to use at regular intervals (at least every three months).
- Please contact your distributor if you have any questions.

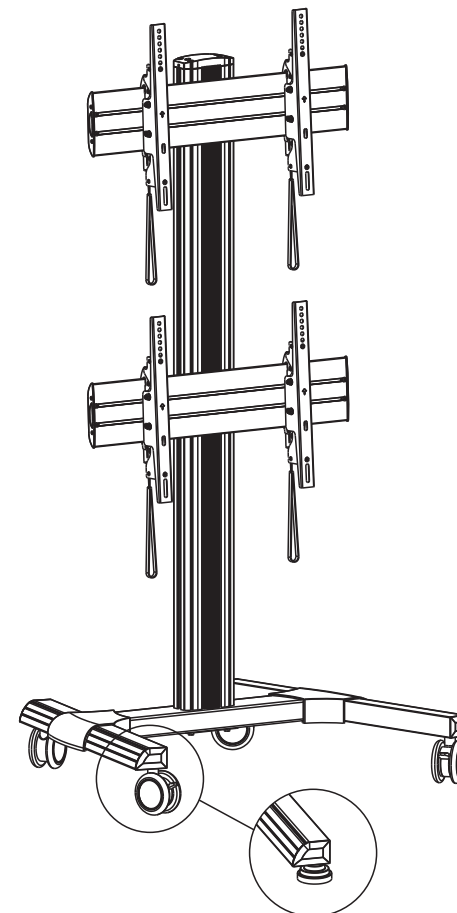

CAUTION: DO NOT EXCEED RATED LISTED WEIGHT. SERIOUS INJURY OR PROPERTY DAMAGE MAY OCCUR!

23215



200x200/300x300
 400x200/400x400
 600x400



55"
 MAX



60kgx2
 (132lbsx2)
 RATED

ISSUED: FEB. 2014

NOTE: Read the entire instruction manual before you start installation and assembly.

⚠ WARNING

- Do not begin the installation until you have read and understood all the instructions and warnings contained in this installation sheet. If you have any questions regarding any of the instructions or warnings, please contact your local distributor.
- This mounting bracket was designed to be installed and utilised **ONLY** as specified in this manual. Improper installation of this product may cause damage or serious injury.
- Always use an assistant or mechanical lifting equipment to safely lift and position the equipment.
- Tighten screws firmly, but do not over tighten. Over tightening can cause damage to the items, This greatly reduces their holding power.
- This product is intended for indoor use only. Using this product outdoors could lead to product failure and personal injury.

IMPORTANT: Ensure that you have received all parts according to the component checklist prior to installation. If any parts are missing or faulty, telephone your local distributor for a replacement.

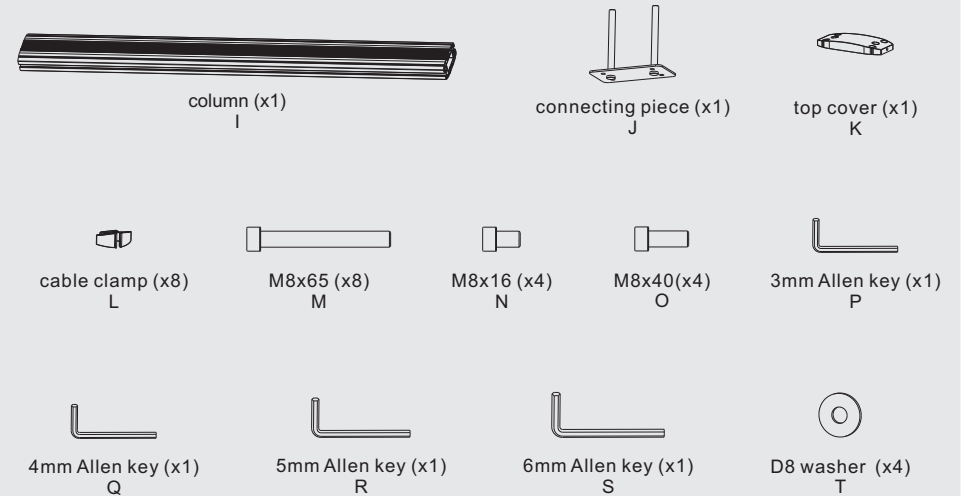
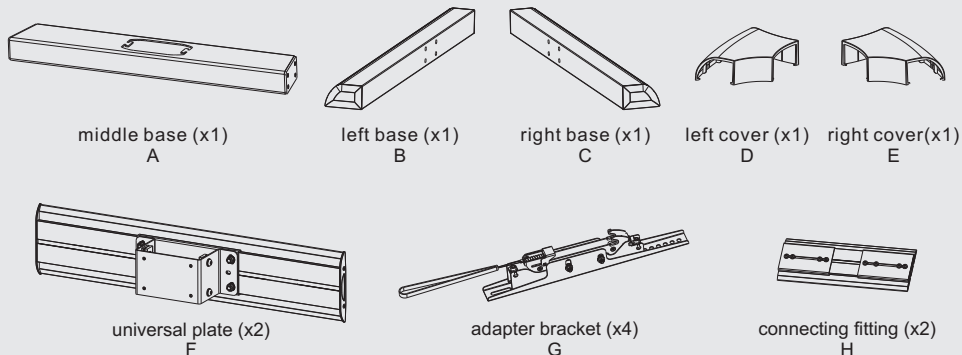

Package M (x2)

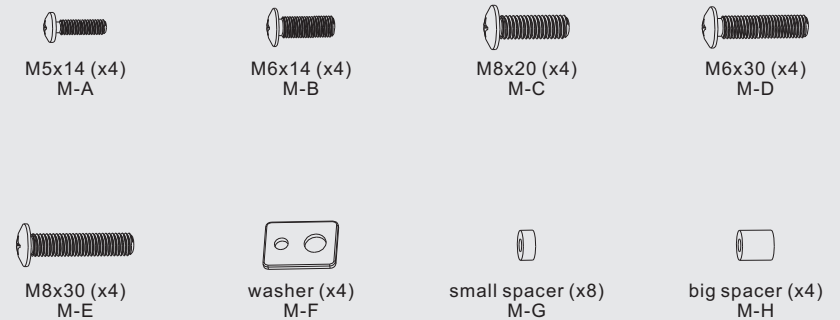

1. Assembling the Base

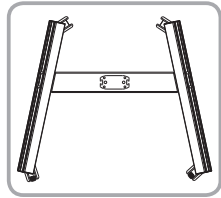
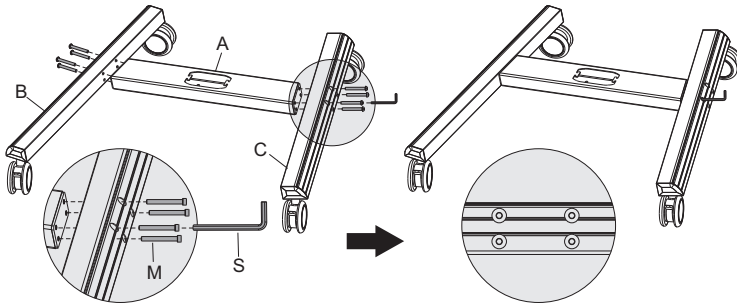

Note: With the brake wheels facing forward.

Attach the left and right base to the middle base using the appropriate screws. Tighten all screws with an Allen key.

2. Attaching the Column to the Base

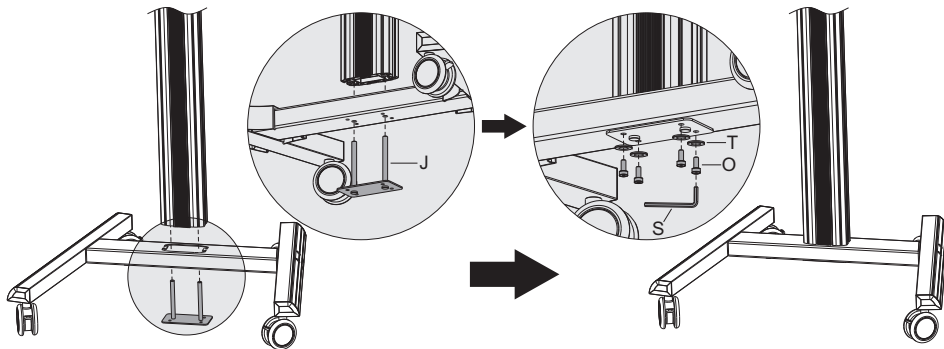

Attach the column to the assembled base using the connecting piece, secure them with the appropriate screws.
NOTE: Lock the brakes on the casters to avoid any sudden movements during installation.

3. Installing the Covers

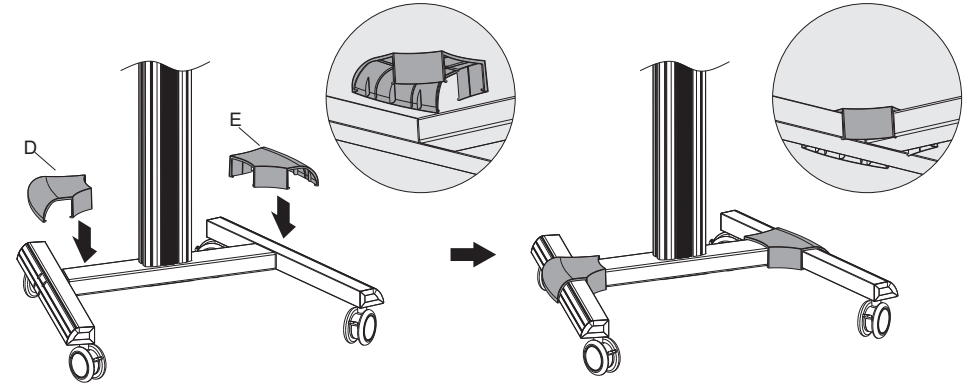

4. Installing the Universal Plates

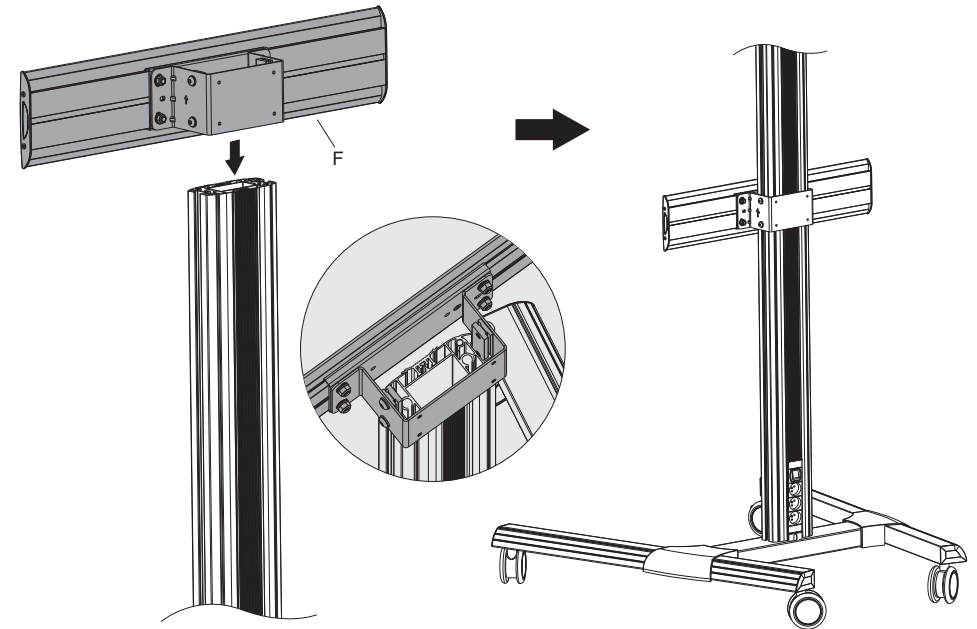

Insert the universal plates to the column along the column rails respectively.
NOTE: With the arrow pointing upward.

5. Installing the Top Cover

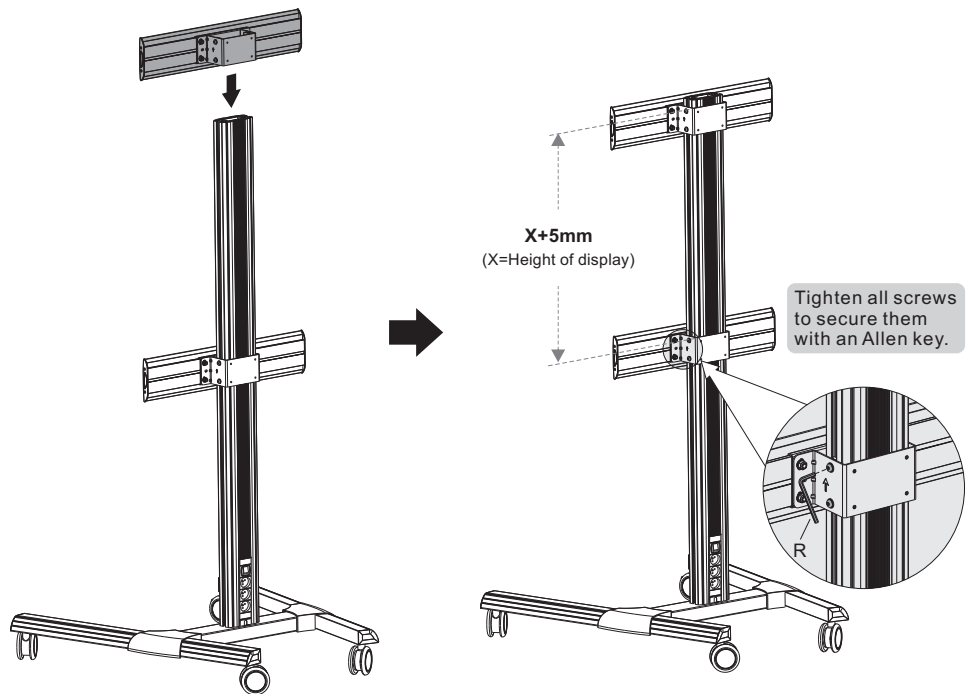

6. Installing the Adapter Brackets

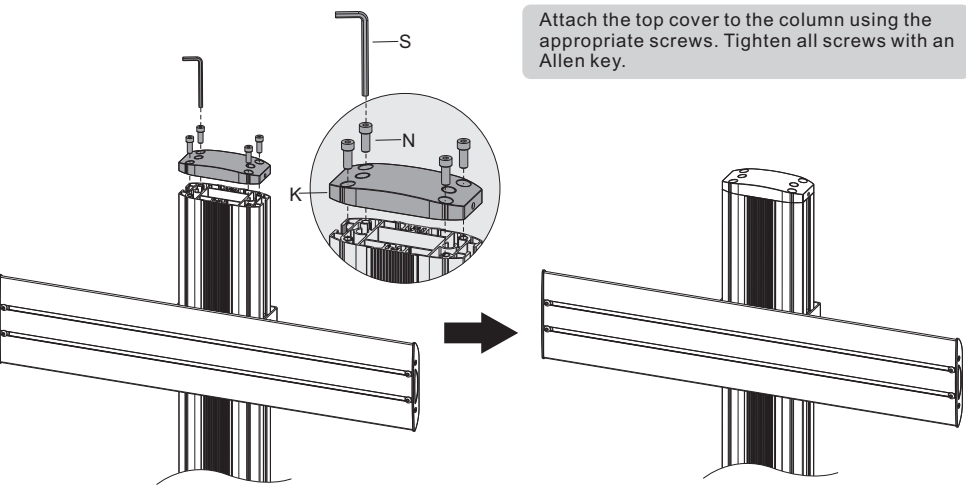

6. Installing the Adapter Brackets

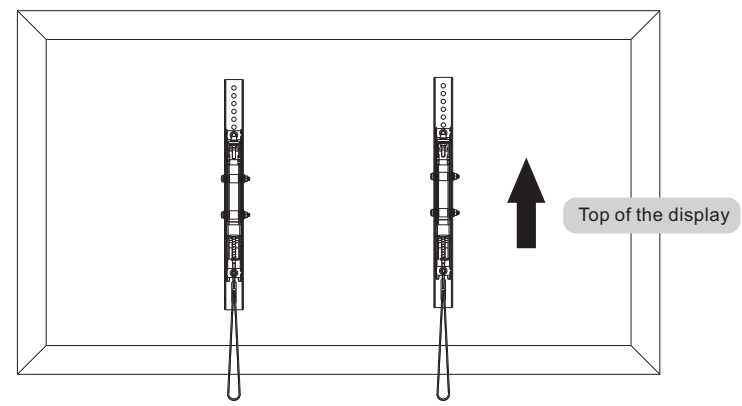

6-1 For Flat Back Screens

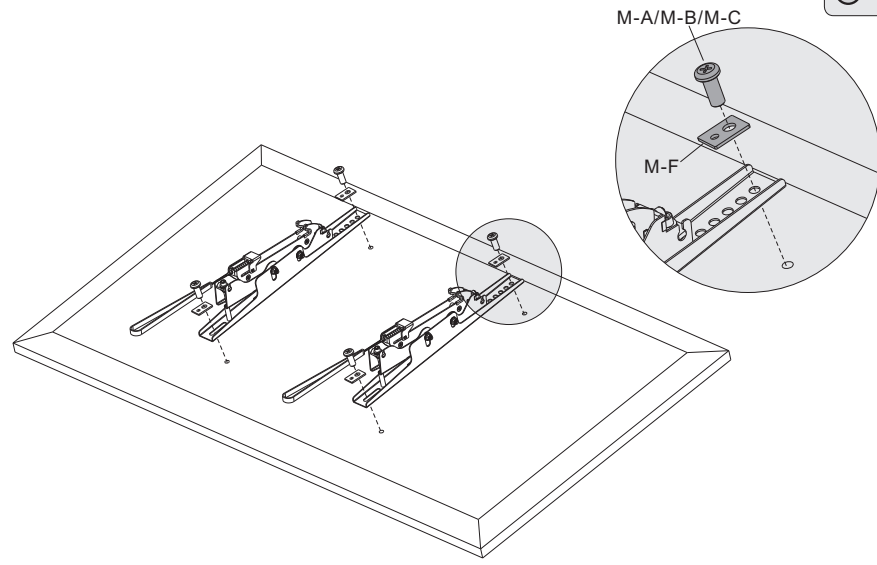

6-2 For Recessed Back Screens or to Access A/V Inputs

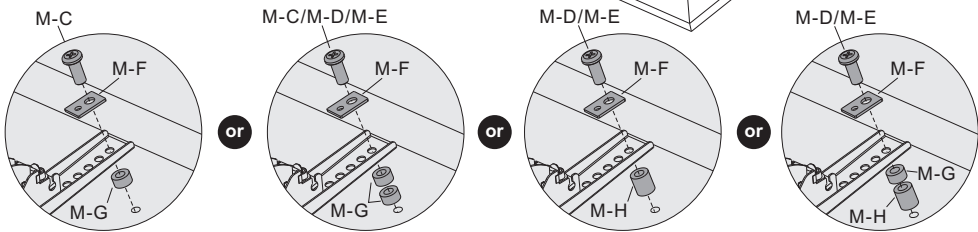
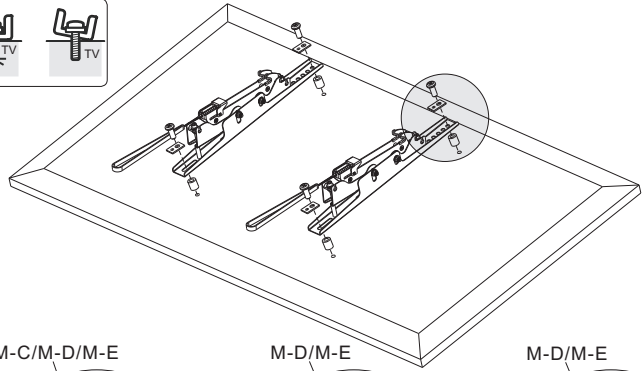
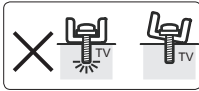
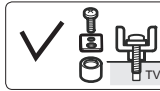

Note: Choose the appropriate screws, washers and spacers (if necessary) according to the type of screens.

- Position the adapter brackets as close as possible to the center of the displays.
- Screw the adapter brackets onto the displays.

⚠ Tighten all screws but do not over tighten.

7. Hanging the Displays onto the Universal Plates

Note: The displays are installed to the universal plates from the bottom up.

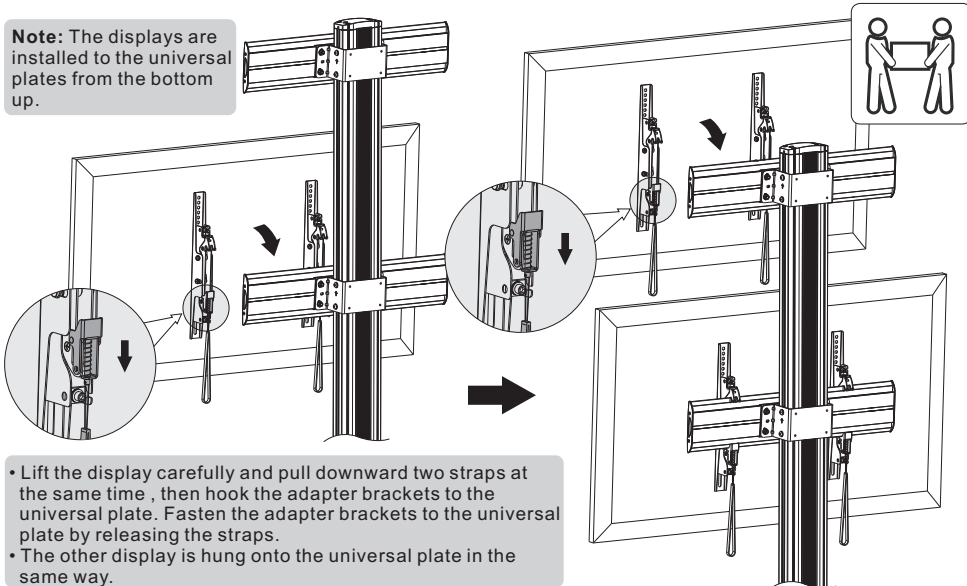

- Lift the display carefully and pull downward two straps at the same time, then hook the adapter brackets to the universal plate. Fasten the adapter brackets to the universal plate by releasing the straps.
- The other display is hung onto the universal plate in the same way.

8. Micro-Adjustment

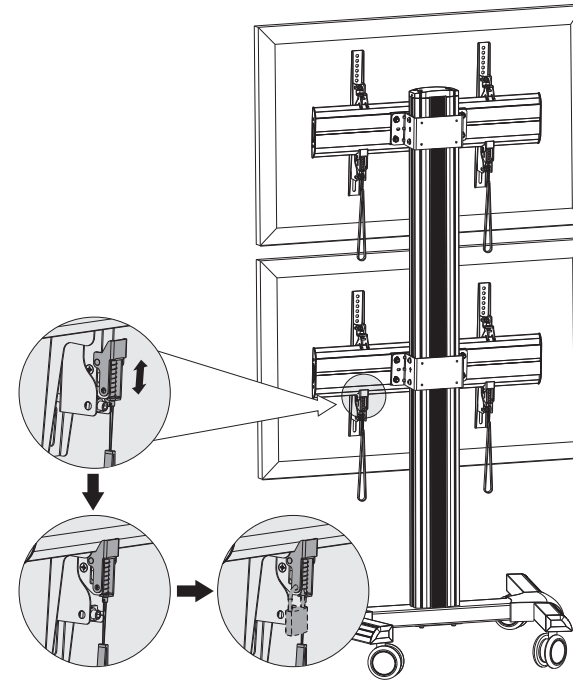

Use the padlocks to prevent the displays from being stolen (The padlocks are not included).

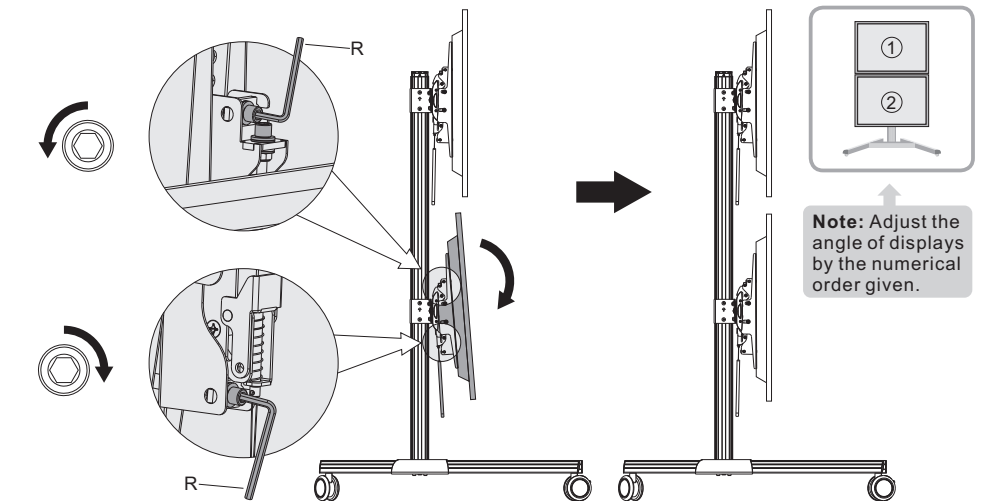

Note: Adjust the angle of displays by the numerical order given.

If the displays uptilted, rotate the adjustment screws as shown in figure.

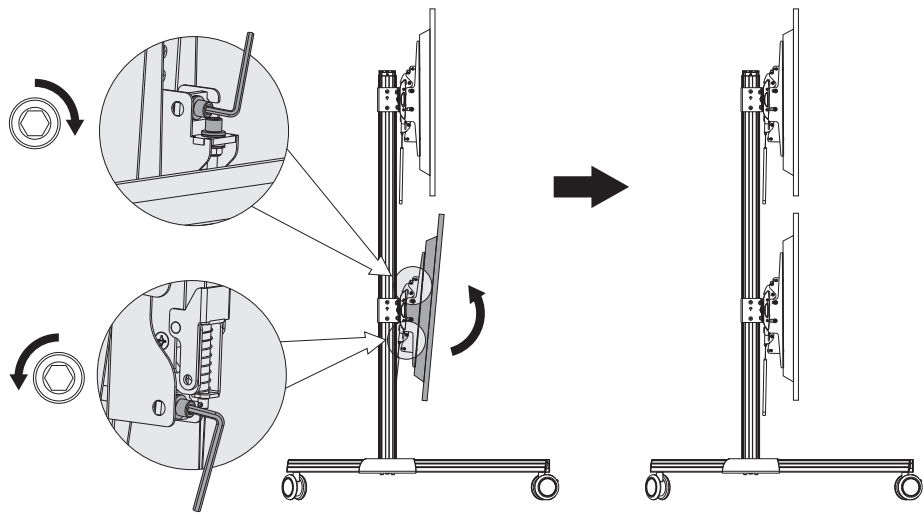

If the displays tilted down, rotate the adjustment screws as shown in figure.

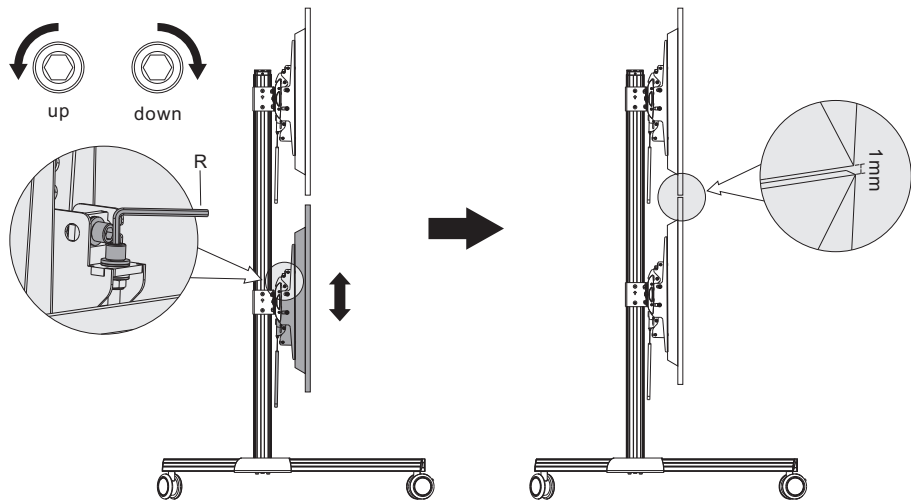

Rotate the adjustment screws as shown in figure to make a one millimeter gap left between the upper and lower displays.



9. Cable Management

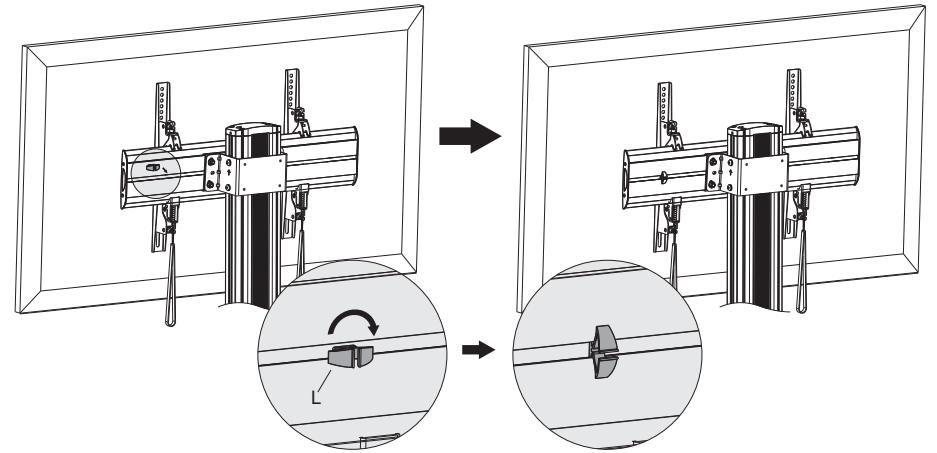

Insert the cable clamps horizontally into the plate slots, then turn the cable clamps to the vertical to secure them.

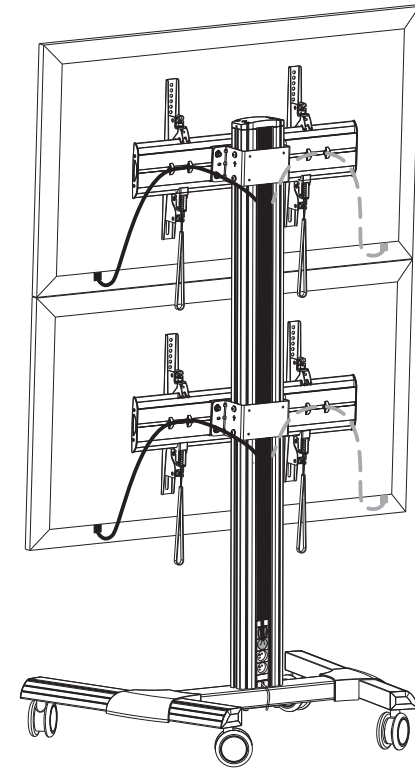

Run the cables through the cable clamps and the rubber strip.

10. Adjustment

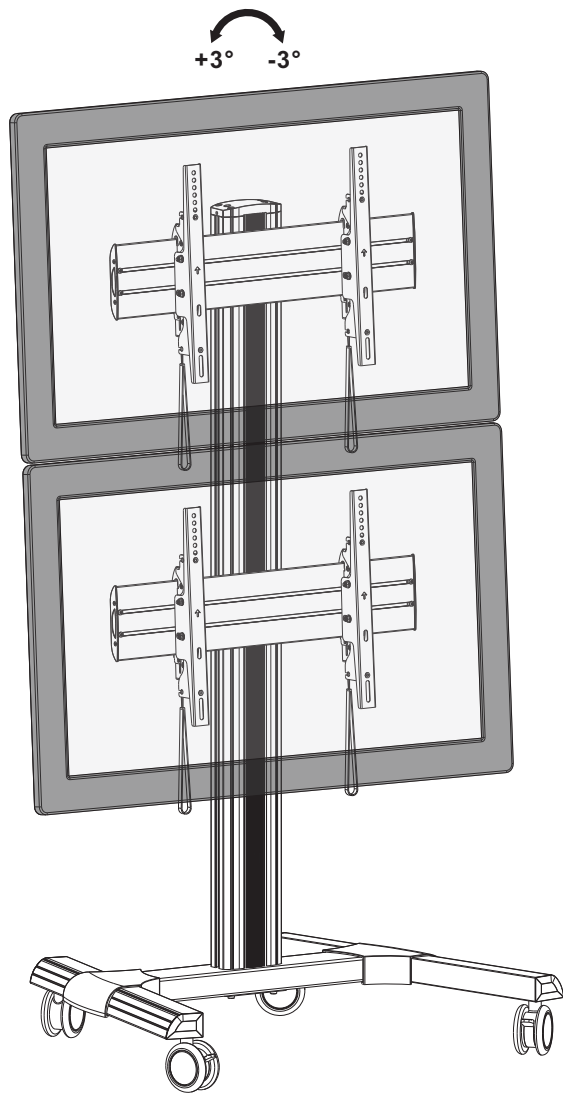

11. Multi-screen Combination Solution

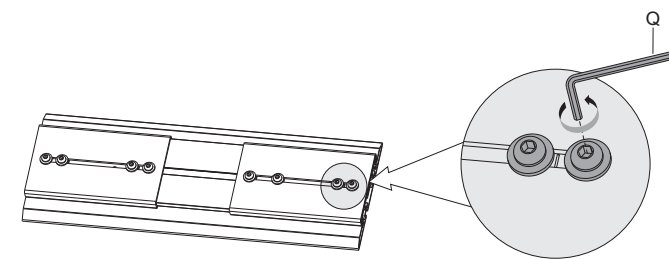
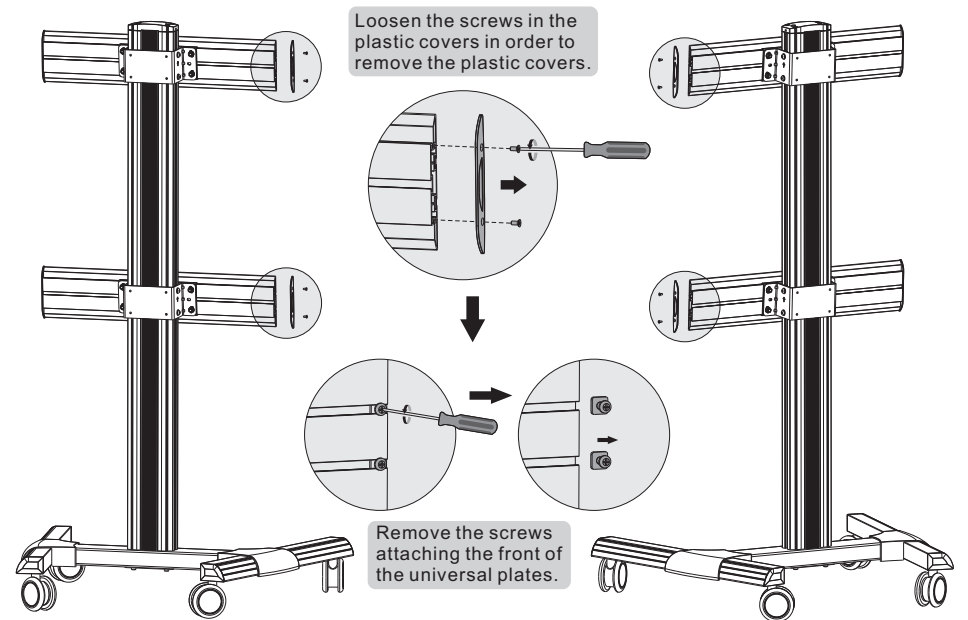

Loosen the screws in the connecting fittings in order to slide the connecting attachments to both sides of the connecting fittings. Then tighten all screws to secure.

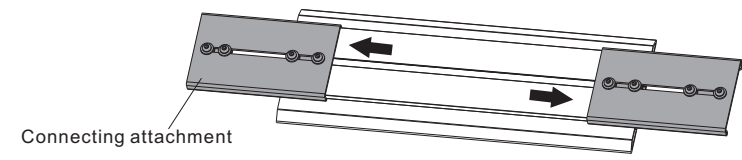

11. Cable Management

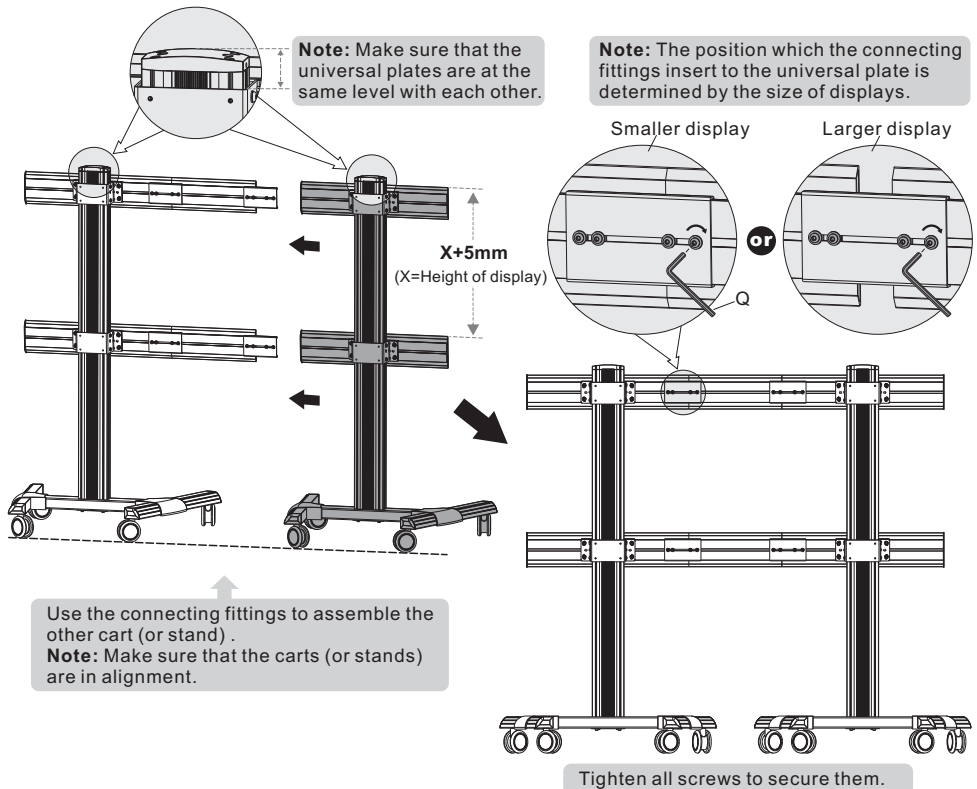
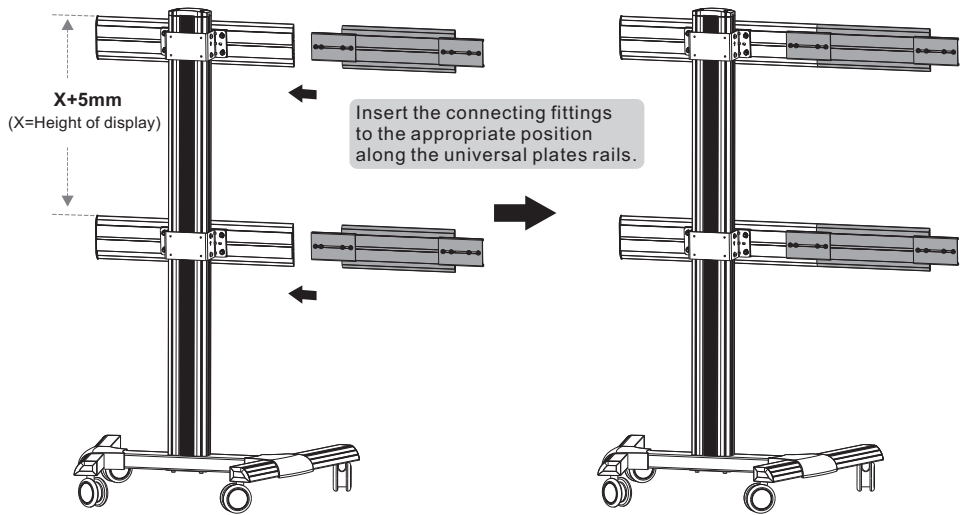

12. Cable Management

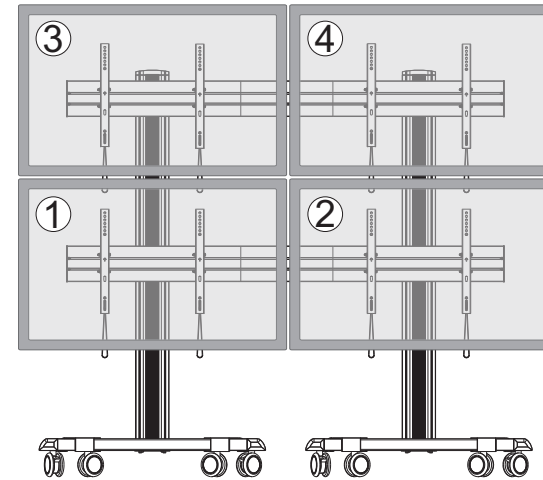

Note: The displays are installed by the numerical order given.

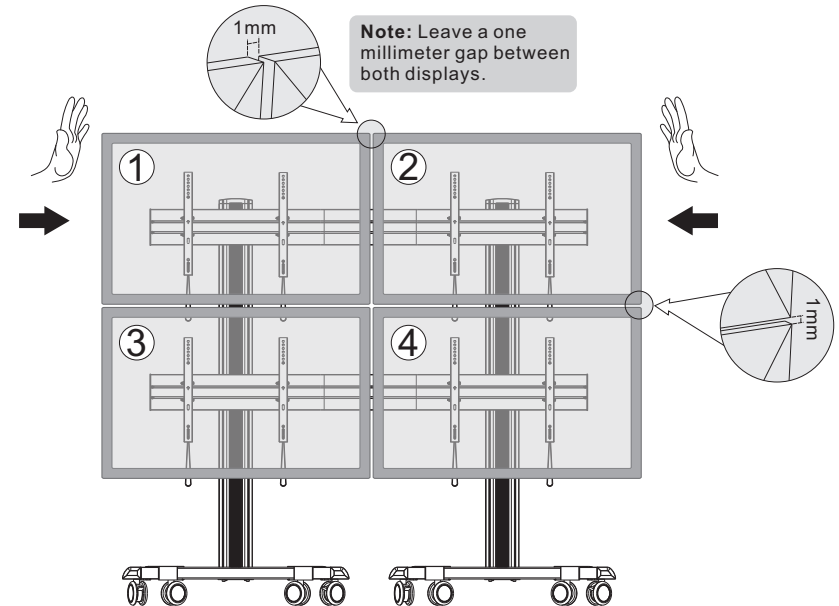

Note: The angle of displays are adjusted by the numerical order given.