

reflecta Projection Trolley Basic

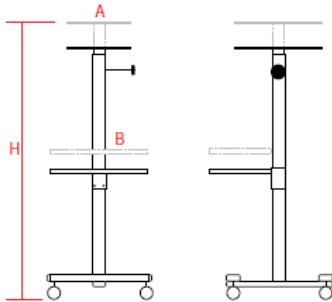

LCD Projection Trolley Basic
 LCD trolley with laptop shelf, height adjustable from 70 to 110 cm. The LCD trolley have one shelf. Equipped with four wheels with two locking castors.

reflecta

Technische Daten

- with 1 laptop shelf
- For wheels with two locking castors
- Technical data:

| | Mounting Plate A | Shelf Plate B |
|-----------------|---------------------|------------------|
| LxW cm | | 40 x 30 |
| Height (H) cm | 70 - 110 | 20 - 60 |
| Inclination 25° | (-5° - 20°) | |
| Load capacity | 25 kg | 5 kg |

Art.-No. 6059
 EAN-Code: 4005039060595

- **Dimension:** 50 x 48 x 70cm (L x Wx H)
- **Weight:** 8 kg **Extend of delivery:** projection trolley

Technical data are subject to change



reflecta GmbH

Junghansring 70
 D 72108 Rottenburg-Ergenzingen
 Phone: +49 (0) 7457 9465-60
 Fax: +49 (0) 7457 9465-72
 e-mail: mail@reflecta.de
 http: www.reflecta.de